



Installation and Operation Manual

Table of Contents

Yacht Crane Assembly	1
Notice to Installer	2
Required Equipment and Tools	3
Supplied Equipment List	3
Optional Equipment List	3
Recommended Materials (not supplied)	3
Required Tools	4
Planning the Installation	5
Choosing the Installation Method	5
Locating the Crane System	5
12ft to 18ft Reach Table	6
11ft to 16ft Reach Table	7
13ft to 20ft Reach Table	8
Installing the Standpipe	9
Hydraulic and Electrical Connections	10
Completing and Testing the Installation	12
Bolt Torquing Recommendations	13
Operating Instructions	14
WARNING: REVIEW BEFORE OPERATING	14
Misuse of the crane may result in injury or death	14
Operating Instructions	14
Crane Storage	15
Maintenance	16
Maintenance Schedule	16
Safety Cautions	16
Troubleshooting	17
Specifications	18
Electrical System	18
Hydraulic System	18
Equipment Dimensions	18
2 Year Platinum Warranty	19
Contact Information	21
Appendix	23

Yacht Crane Assembly

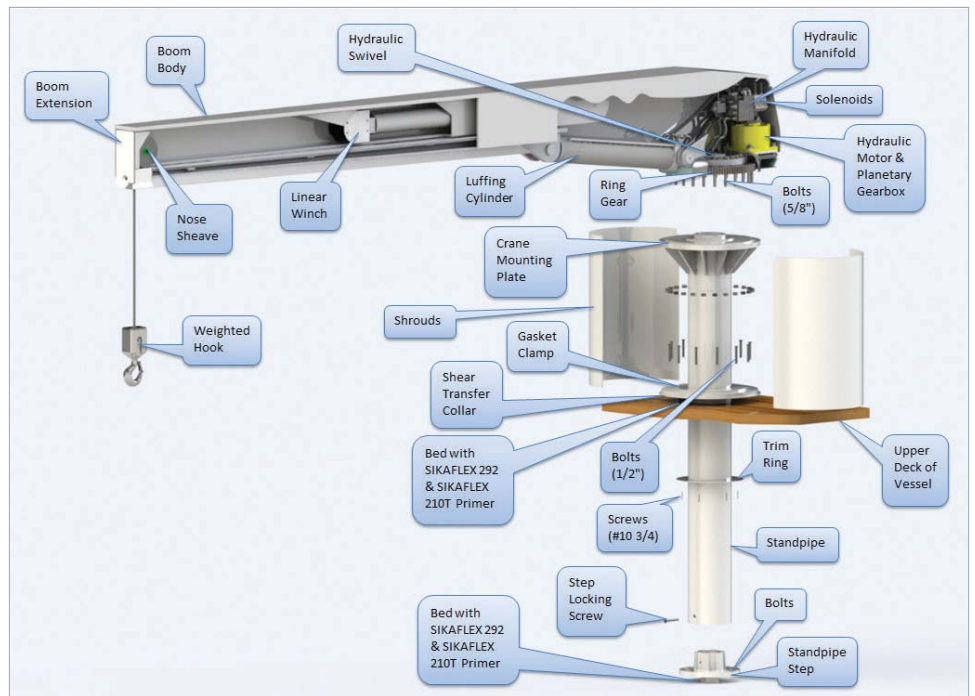



Figure 1a: Standpipe Mounted



Figure 1b: Square Base Mounted

Notice to Installer

Throughout this publication, Warnings and Cautions accompanied by the International Hazard Symbol  are used to alert the manufacturer or installer to special instructions concerning a particular service or operation that may be hazardous if performed incorrectly or carelessly.

Observe Them Carefully!

These “safety alerts” alone, cannot eliminate the hazards that they signal. Strict compliance to these special instructions when performing the installation and maintenance plus “common sense” operation are major accident prevention measures.

DANGER

Immediate hazards which WILL result in severe personal injury or death.

WARNING

Hazards or unsafe practices which COULD result in severe personal injury or death.

CAUTION

Hazards or unsafe practices which COULD result in minor injury or product or property damage.

NOTICE

Information which is important to proper installation or maintenance, but is not hazard-related.

Required Equipment and Tools

This section describes the equipment and tools needed or recommended for the yacht crane installation.

Supplied Equipment List

Your yacht crane comes with the following standard equipment: Crane assembly, complete with:

- bearing assembly installed
- hydraulic and electrical system installed
- composite rope, hook and weight assembly installed
- 360 degree rotary swivel **c/w 2 male #6 JIC connections and 3 conductor electric swivel (if required)**
- 4-function, hand-held, pendant control c/w 20' cable
- Owner's Handbook and Installation Manual
- (24) 5/8" x 3 1/2" 316 SS FHMS (high strength) c/w nuts, FW & LW

Optional Equipment List

- **Customized base assembly** (built to your specification)
- OR** • **Standpipe assembly containing:**
 - 9' standpipe (adjustable height to suit your requirements).
 - shear transfer collar
 - Standpipe foundation step
 - trim ring
 - Set of shrouds
- Hydraulic power pack, available in 24V, 230VAC single phase
- Hydraulic supply manifold (required on load sensing systems)
- 1/2" Amsteel replacement rope kit c/w eye splices (includes installation instructions)

Recommended Materials (not supplied)

You will need all or most of the following materials for the crane installation:

- (12) 1/2" FHMS for thru-bolting (sheer transfer collar)
- (10) 5/8" FHMS (standpipe step)
- (6) #10 x 3/4" OHST screws (trim ring)
- Sikaflex 292, Sikaflex 210T primer
- anti-corrosion paste (Tef-Gel)
- marine corrosion control grease
- heat-shrink-type electrical connectors
- 16/3 electrical cable, length as required
- electrical breakers

Required Tools

You should have the following tools on hand for installation:

- tape measure
- masking tape
- caulking gun
- drill motor
- portable band saw, or Sawzall power saw
- Phillips screwdrivers
- utility knife
- level
- holesaw (3 3/4")
- assorted drill bits
- 3/8"-16 tap and handle (optional)
- assorted metal-working files
- wire strippers/cutters
- heat shrink tubing and gun
- wet/dry vacuum
- safety goggles and/or face shield

Planning the Installation

Choosing the Installation Method

There are three ways to install the crane:

- 1. Bolting Directly Onto Deck** – The crane can be bolted directly onto the deck if the yacht structure has been designed and built to accommodate the load. The rotary swivel prevents any hose rotation. **A paper template of mounting hole pattern can be supplied if requested.**
- 2. Custom Base Assembly** – Steelhead Marine can design and build custom base assemblies to your specific requirements, to be installed by an experienced shipyard. Contact Steelhead for more information.
- 3. Standpipe Assembly** – To install the optional standpipe assembly, *see procedure on page 9* (max step to mounting plate height 133 ³/₄").

Locating the Crane System

- Choose the best storage location for your tender considering the following factors:
 - clearance needs to allow for rotation and storage of crane (check walk-around space, hatch, railing, and other clearances)
 - deck strength
 - standpipe base location on lower deck
 - accessibility for easy operation and maintenance
- Determine the balance point of the tender, and mark this balance spot on the deck. The reach requirement of the crane is a horizontal measurement from the optimum crane location to the balance point of the tender.
- To ensure the tender does not hit the side of the vessel during a launch and retrieval, allow 9" more than the tender's half beam measurement for clearance (i.e., half the width of the tender).
- Check crane hook height vs. reach table at various luffing angles to ensure at least 8" of clearance between the tender and vessel (railings) during operation.
- Double-check the reach and height requirements against the specifications of the crane to ensure the crane will meet your installation requirements.

12ft to 18ft Reach Table

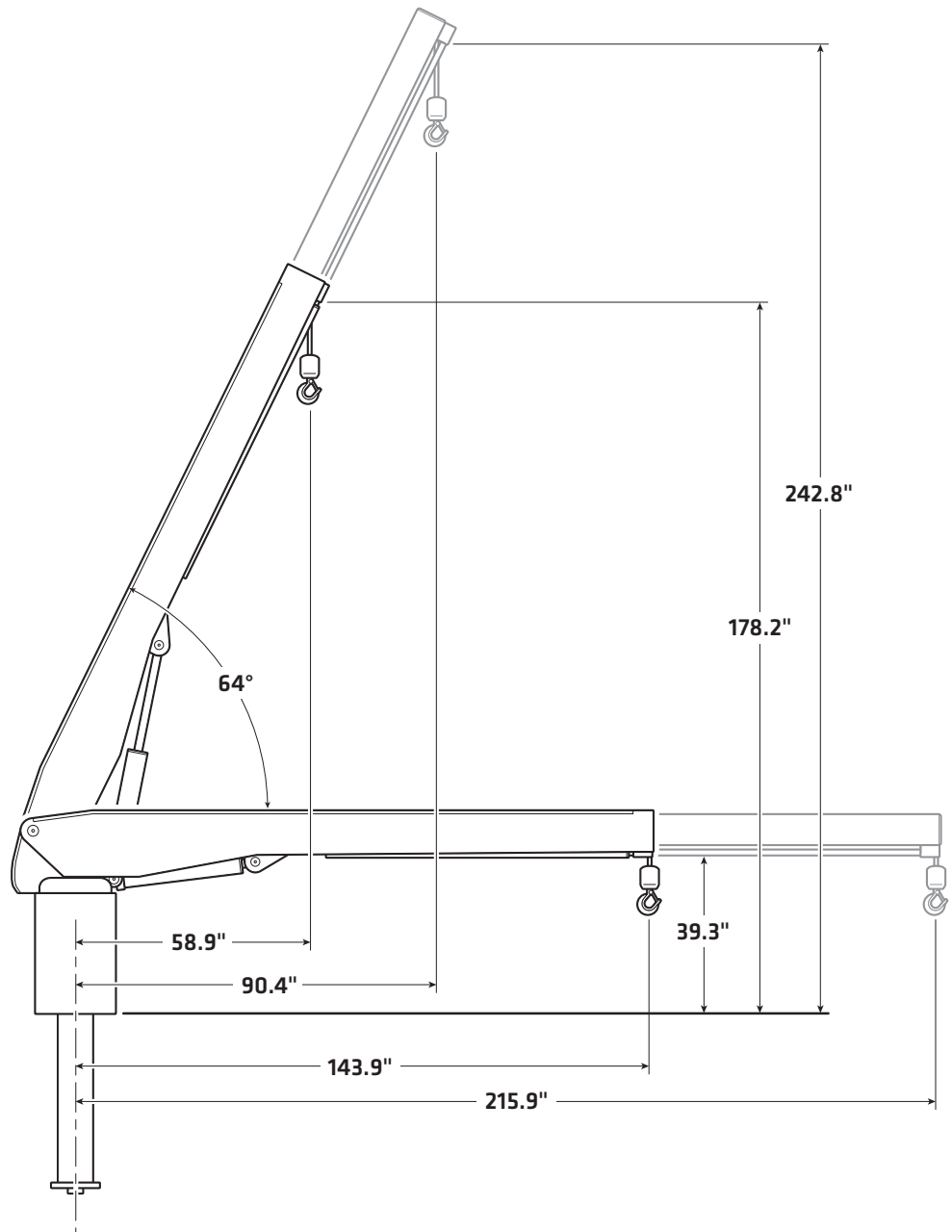

Angle	Length	Height
0°	215.9"	39.3"
10°	212.5"	78.0"
20°	202.4"	115.8"
30°	186.0"	151.4"
40°	163.7"	183.8"
50°	136.1"	212.0"
60°	104.2"	235.1"
64°	90.4"	242.8"

Figure 2a: Reach Table - 12ft to 18ft Reach

11ft to 16ft Reach Table

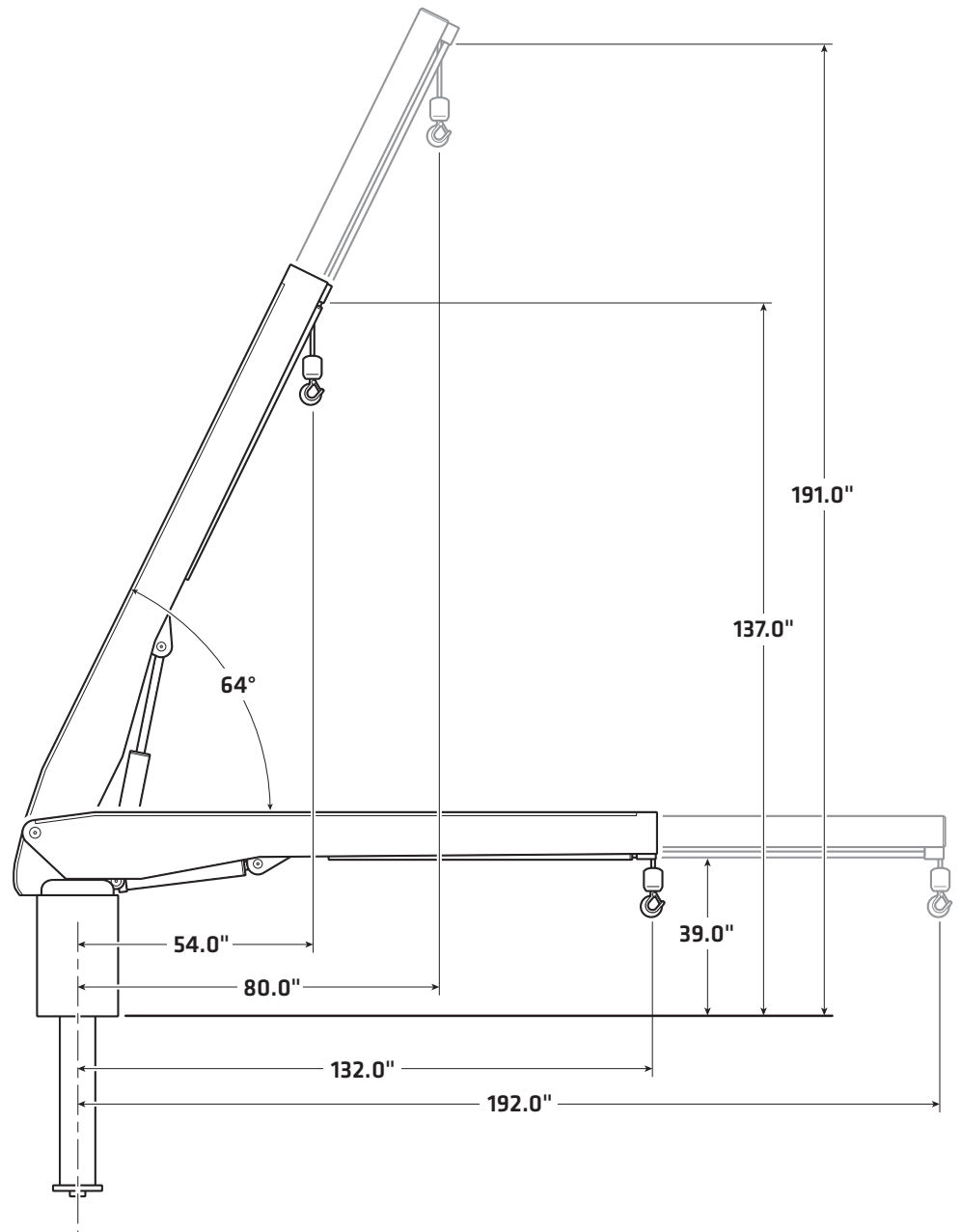

Angle	Length	Height
0°	192.0"	39.0"
10°	189.0"	73.0"
20°	180.0"	77.0"
30°	165.0"	109.0"
40°	145.0"	138.0"
50°	121.0"	164.0"
60°	92.0"	184.0"
64°	80.0"	191.0"

Figure 2b: Reach Table - 11ft to 16ft Reach

13ft to 20ft Reach Table

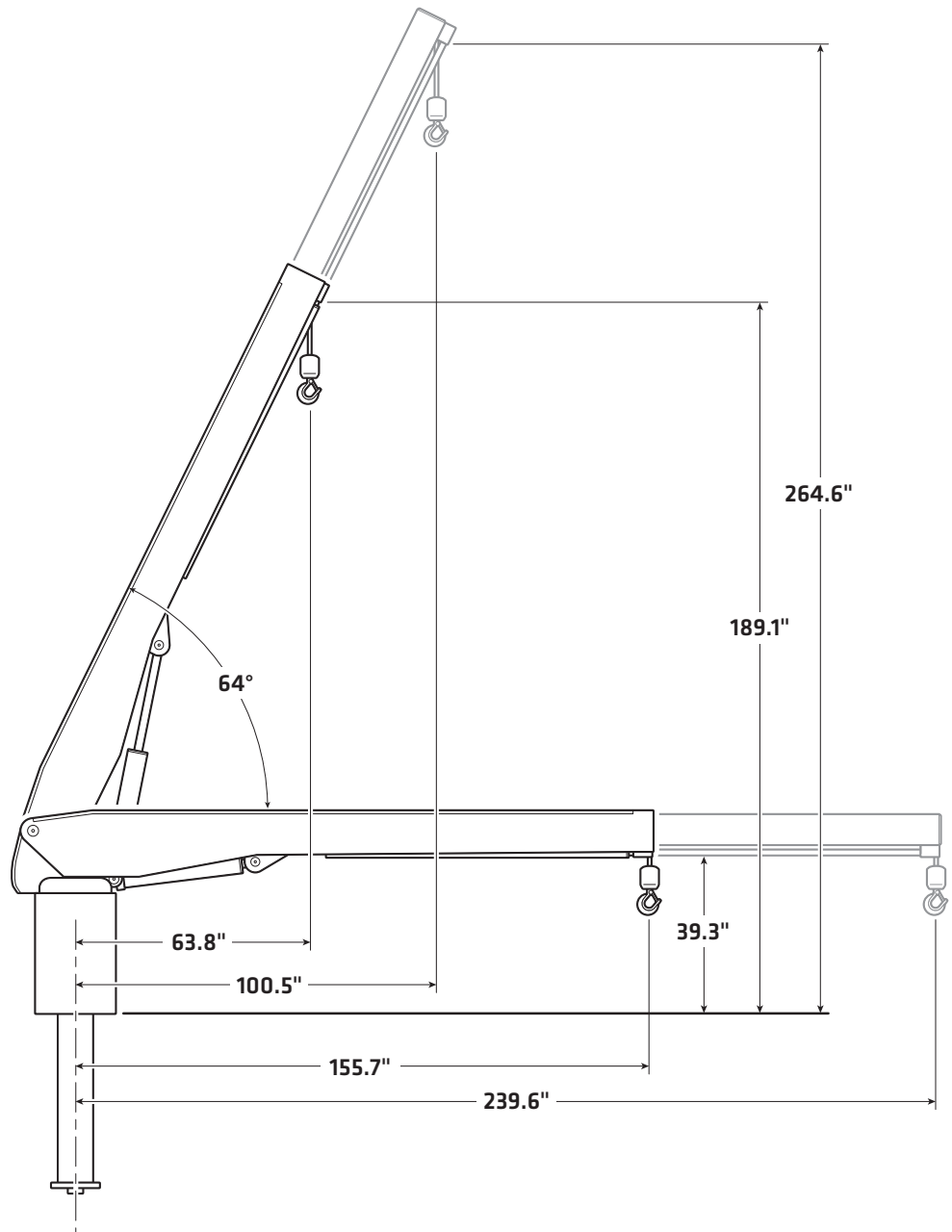

Angle	Length	Height
0°	239.6"	39.3"
10°	235.7"	82.0"
20°	224.4"	123.8"
30°	206.2"	163.9"
40°	181.4"	199.2"
50°	150.9"	230.4"
60°	115.6"	256.0"
64°	100.5"	264.6"

Figure 2c: Reach Table - 13ft to 20ft Reach

Installing the Standpipe

NOTICE

There are three parts to the shear transfer collar: a 20" diameter base, a rubber gasket, and an 14 3/4" diameter gasket clamp.

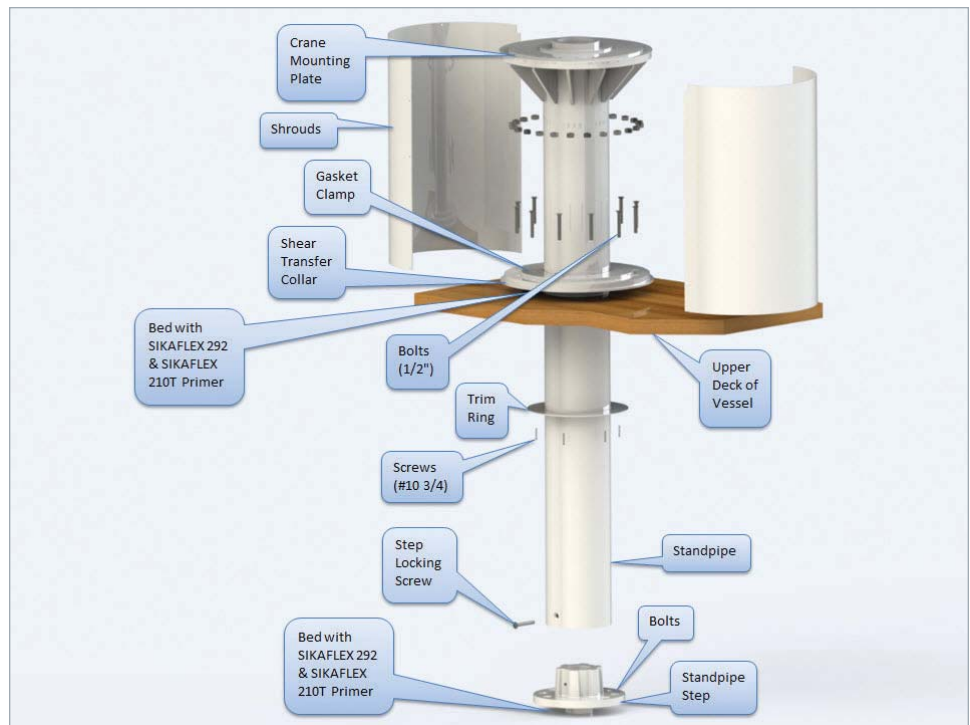

Figure 3: Exploded View of Standpipe

NOTICE

When the standpipe is installed correctly, there will be a 1/4" gap between the shroud and the shear transfer collar. The shroud will be screwed to the underside of the crane mounting plate, but not until the end of the installation. You must take the measurement described in Step 7 when the standpipe is placed over top of the standpipe step on the lower deck. The measurement must be 1/4" longer than the length of the shroud (17 1/4") and the bottom of the standpipe will need to be trimmed accordingly.

1. Locate the standpipe in the chosen location for the tender and mark its centerline on both upper and lower decks. The standpipe must be installed vertically plumb without contacting the vessel between decks while flexing under load.
2. Drill 1/4" pilot hole in upper deck and re-check centers for clearance. The upper deck must be leveled 90 degrees to standpipe or shroud will have to be trimmed to fit.
3. Cut 9" hole through upper deck.
4. Mount shear transfer collar to upper deck by drilling through the upper deck (twelve 1/2" clearance holes for thru-bolting).
5. Clean deck surface and mount shear transfer collar by bedding with Sikaflex 292 and Sikaflex 210T Primer and installing fasteners through holes on 20" diameter base of collar (using bolts as per Step 4).
6. Seal deck core material and clean off excess sealant.
7. With assistance from below, lower standpipe through collar to lower deck. Mark location of standpipe step on lower deck.
8. On lower deck, drill 3 3/4" hole through center of standpipe step location for standpipe step spigot.
9. Drill ten 11/16" holes.
10. Seal deck core material as directed by shipyard, chock standpipe step spigot with FRP filler material and bed standpipe step with Sikaflex 292 and Sikaflex 210T Primer.
11. Install step fasteners to secure step onto deck floor.
12. With assistance from below, reinstall standpipe, sliding trim ring over bottom of standpipe before placing over step (the trim ring will attach to ceiling of lower deck). Ensure that the standpipe contacts standpipe step evenly all the way around, with outer lip of step protruding.

13. Drill and tap $\frac{3}{8}$ " bolt through standpipe into step to lock standpipe into position.
14. Secure collar clamp and gasket to shear transfer collar by tightening the twelve $\frac{3}{8}$ " bolts evenly. These bolts compress sealing gasket on collar and lock standpipe into position on upper deck.
15. Mount trim ring to ceiling of lower deck using four screws.

Hydraulic and Electrical Connections

To install the crane's hydraulic and/or electrical connections:

1. Lead two #6 hydraulic lines from ship's hydraulics (or power pack), to top of standpipe mounting plate. Add 12" extra length for connection.
2. Lead $\frac{3}{16}$ electrical wire from ship's main breaker and power pack or hydraulic manifold to crane mounting plate. Again, add 12" extra length for connections.
3. Remove access covers from crane assembly base.
4. Lower crane to within 12" of mounting plate (on standpipe, deck, or custom base assembly), then make hydraulic connections by connecting pressure line to P port on hydraulic swivel.
5. Complete electrical connections *as per wiring diagram on page 11*, and use heat shrink to seal connections from corrosion.
6. Complete hydraulic and electrical connections at ship.
7. Connect pendant hand control by plugging it into connection on boom.

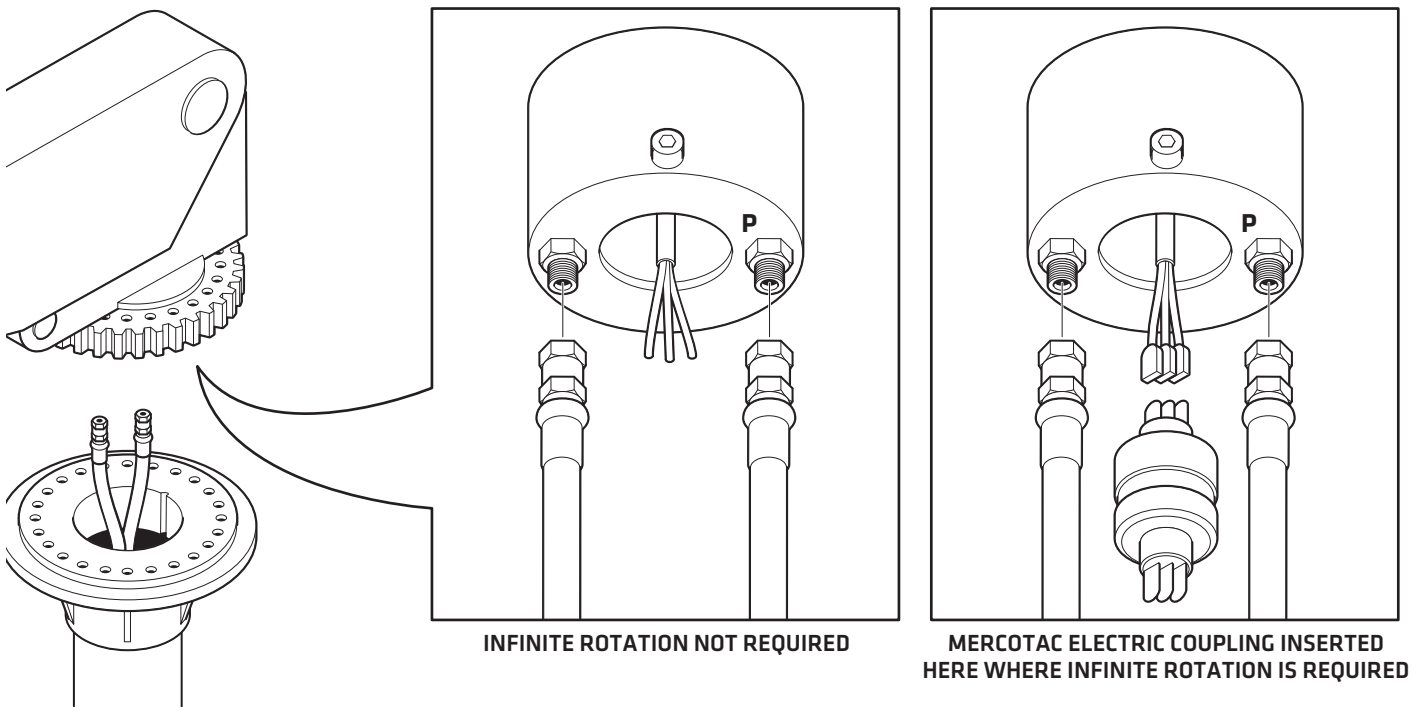

Figure 4: Crane Hydraulic Connections

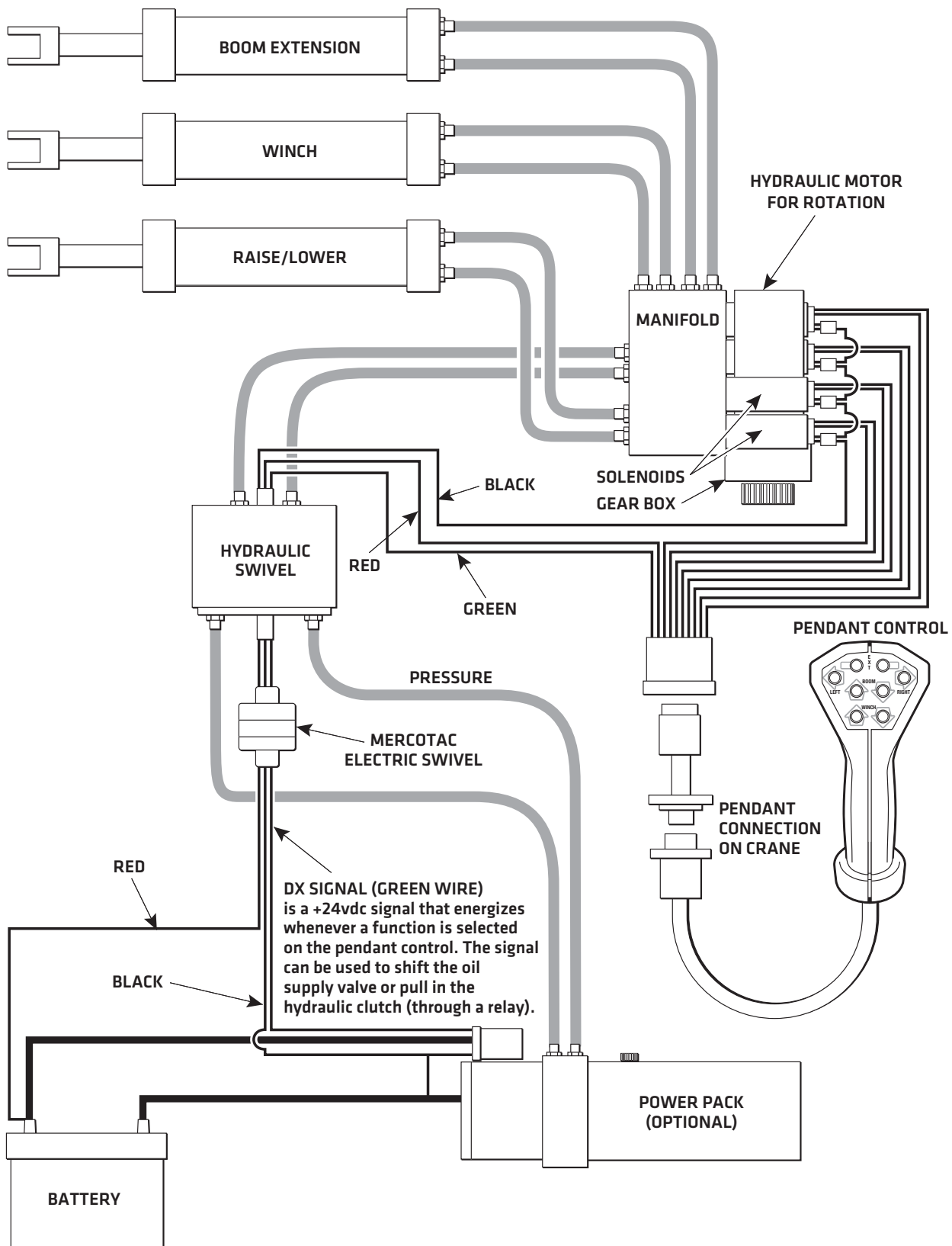

Figure 5: Electrical and Hydraulic Connections

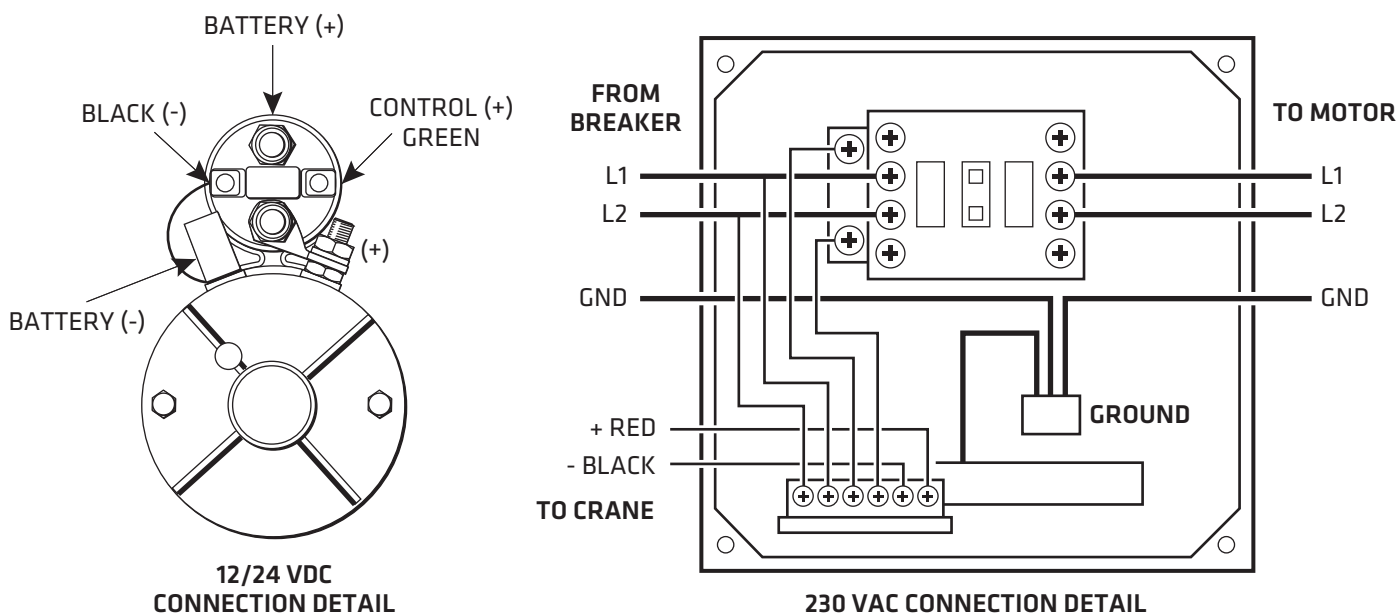



Figure 6: Wiring Connections

Completing and Testing the Installation

To complete and test the installation of the crane:

1. Lower crane onto mounting plate, ensuring that the hydraulic swivel fits correctly into the 4 ³/₄" diameter hole and retaining notch in center of mounting plate.
2. Install 24 mounting bolts, 5/8" x 3 1/2", and torque to recommended values (*see next page*).
3. Retract both hydraulic cylinders. Fill hydraulic reservoir tank with **AW 32 Hydraulic Oil**.
4. Test crane as follows:
 - Turn breakers on momentarily.
 - Ensure power unit turns on.
 - Check all wiring.
 - Check hydraulic source and ensure correct pressure from pressure port.
 - Turn on control breaker.
 - Lightly touch each button on the pendant hand control to make sure crane moves appropriately.
5. When systems are confirmed correct, recheck oil level in reservoir and refill to 1" level.
6. Rotate crane 90° and turn power off.
7. Install eight remaining mounting bolts (5/8" x 3 1/2") on crane mounting plate and tighten as previously directed. (Crane always covers eight bolts, so crane must be rotated to expose them.)
8. Reinstall crane access covers.

- 
9. Slide shroud over the crane mounting plate and attach it to the underside of the plate using $\frac{8}{32}$ " screws. Use Tef-Gel where stainless screws contact painted aluminum surfaces to prevent paint blistering and corrosion.
 10. During shipment, air may have collected in hydraulic system. To bleed, operate all boom functions through their full travel capacity 3 or 4 times, using pendant hand control. This will remove any air in the system.
 11. Recheck oil level in reservoir to ensure 1" level has been maintained.

Bolt Torquing Recommendations

1. Use thread lubricant (i.e. moly disulfide grease) on threads before beginning to torque bolts.
2. Apply snugging torque of 50 lb-ft in a cross or star pattern.
3. Optional: Apply torque of 75 lb-ft in a second pass using same order.
4. Apply final torque of 100 lb-ft using the same order.

Operating Instructions

WARNING

REVIEW BEFORE OPERATING.

Misuse of the crane may result in injury or death.

Always follow carefully these safety cautions:

- Never load the crane system beyond its capacity
- Be sure the area around and under the tender is clear of people and obstacles before lowering, including lower decks and water level.
- Remove all cargo and excess water from the tender before raising or lowering.
- Ensure all passengers leave tender before raising and lowering—this crane is not a personnel lift.
- Position the crane directly over the load when operating—the crane is designed for vertical hoisting only.
- Do not launch or retrieve a tender in rough sea conditions, or while underway.
- Be aware that yachts tend to list when launching a tender. Use caution when rotating a load.
- Do not allow children to operate the crane.
- Keep hands away from all moving parts.
- Turn the crane's power supply off when not in use.
- Detach crane from tender and retract boom to stow.

Operating Instructions

1. Turn on hydraulic supply by:
 - activating the ship's hydraulics, OR
 - turning on the ship's main breaker to supply the crane's power pack
2. Remove waterproof plug on crane body and plug in pendant control.
3. Disconnect weighted hook from hook hanger and allow it to hang freely.
4. Attach the tender's lifting bridle to the weighted hook. Using the pendant control (*Figure 7*), position the lifting bridle to enable attachment to the tender.
5. Raise the lifting bridle just enough to remove any slack from the cables. Check all attachments to the tender.
6. Remove the tender's attachments to the deck, and ensure the tender's drain plug is installed.
7. Attach the handling lines to the bow and stern of the tender.
8. Raise the tender high enough to clear all deck obstructions and railings.
9. Rotate the load outboard, controlling the tender position with bow and stern lines.
10. Lower the load to the water. Pay out enough cable so that the tender does not load the cable and crane as it rides waves or swells.
11. Using the load-handling lines, pull the tender to a point near the vessel where it may be boarded. Disconnect the lifting bridle from the tender.
12. Secure the weighted hook so that it does not swing into the side of the vessel.

Crane Storage

To properly store the crane after use:

1. Retract boom extension.
2. Luff crane to horizontal position into boom checks.
3. Pay in the rope completely and install hook into hook hanger under the boom nose .

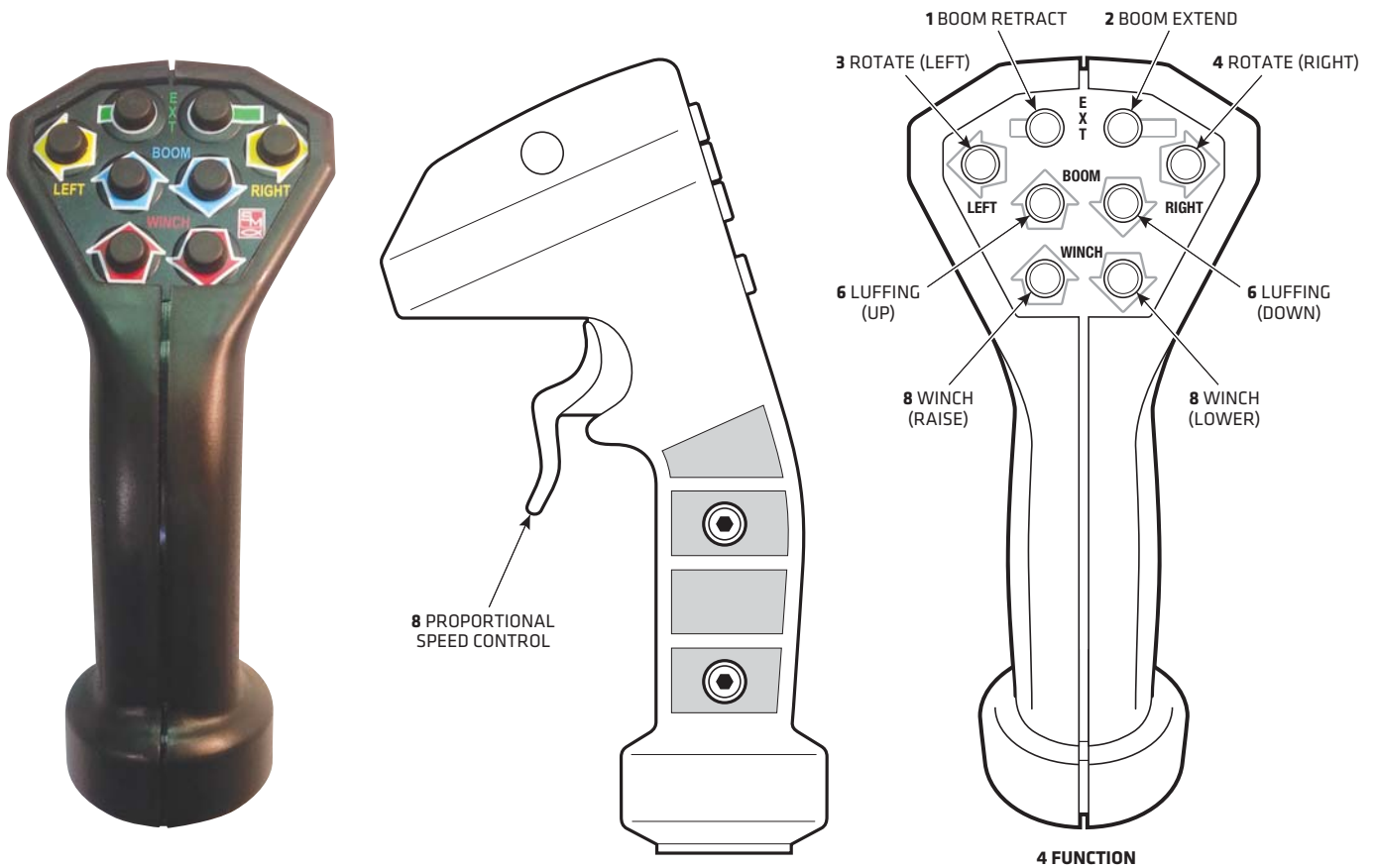

Figure 7: Pendant Control

Maintenance

Maintenance Schedule *(please refer to Figure 1a)*

	Monthly	Quarterly	Annually	As Required
Inspect main hoist cable. Replace upon first sign of frays, fish hooks, flattening, kinks, corrosion, audible pinging or snapping sounds.	✓			
Inspect all cables and hydraulic hoses and fittings. Replace at first sign of corrosion or excessive wear.	✓			
Inspect crane and its hardware components for signs of damage or malfunctioning parts.			✓	
Touch-up any paint damage to preserve the crane's finish.				✓
Wash crane with soap and water including top sheave and manifold area.	✓			
When cleaning the crane, inspect for hydraulic leaks at the power unit and cylinders. Tighten the fittings as required to stop any leaks.	✓			
Inspect and lubricate the crane rotation bearings.		✓		
Inspect the sheaves.	✓			
Service the hydraulic system annually or after 50 hours of use, whichever comes first.			✓	
Maintain fluid levels at 1" below the top of the reservoir on the crane power unit. Use AW-32 or equivalent non-foaming hydraulic fluid only.				✓
Apply white lithium grease between the rotation gear (ring gear) and pinion gear.			✓	

⚠ Safety Cautions

Death, injury, or damage may result if the crane's cable is not inspected regularly, and replaced as needed.

Counter balances have been factory set for optimal performance; crane safety may be jeopardized by unauthorized adjustments.

If the boom is in a 62° position during maintenance, the boom must be supported to prevent injury to personnel.

Troubleshooting

PROBLEM	PROBABLE CAUSE	SOLUTION
Boom will not extend	Wrong button pressed	<i>See Figure 7 on Page 15</i>
Crane will not luff	No power (control)	Turn control breaker on
Crane will not rotate	No power (ships hydraulic) or No power (powerpack)	Is engine driving the hydraulics running? Turn control breaker or reset if req.
	Breaker (fuse) blown	Check Breaker.
	Pendant Control connection (loose) Battery Connection (loose)	Check all connections (ship side). Call electrician if it persists.
	Low hydraulic oil	Check for leaks and oil level top up if necessary
	Hydraulic control valve (not shifting)	Clean or Replace cartridge valve. Call dealer for instructions
	Control solenoid burnt out	Replace solenoid. Call dealer for instructions
Linear winch does not raise or lower	Wrong button pressed	<i>See Figure 7 on Page 15</i>
	Hook still attached to hook hanger	Disconnect
	Tender not disconnected	Release tender tie downs
	Overload on crane	Check tender for equipment and excess water
	Hook travel exceeded	Max travel 20' hook retracts to within 8" of outer sheave
	Cable jammed inside linear winch	Call Dealer for service or instructions
Winch does not hold weight	Hydraulic components need servicing	Call Dealer for service or instructions
Boom settles under load	Hydraulic components need servicing	Call Dealer for service or instructions
Boom rotates when not under power	Hydraulic components need servicing	Call Dealer for service or instructions

Customer Service

For service, contact the dealer from which you purchased the yacht crane. Contact information is on the last page of this manual.

Specifications

Electrical System

- The crane's electronic control system is available as 24 volt, 3 amps
- Hand held pendant with 20' cord provides 2-way, 4-function control and connects to crane body with waterproof plug and cap. Low voltage output automatically starts hydraulic power pack or ship's hydraulics.

Hydraulic System

- Operational pressure is 2,500 psi.
- Hydraulic power is supplied by ship's hydraulics or Steelhead Marine power packs, which are available in the following voltages:
24 volt DC, High output, 208 amps
230 volt AC, 5HP, 1 phase, 60 HZ, 22 amps
- **Slewing** – rotation is powered by a hydraulic motor driving a pinion gear on the main bearing. The motor is counterbalanced to lock when not operational.
- **Luffing** – boom elevation, a counterbalance cylinder locks boom at any angle between 0 and 64 degrees
- **Winch** – 6 to 1 linear winch provides quiet lowering and hoisting
- **Extension** - boom length adjustable under load

Equipment Dimensions

	HEIGHT	WIDTH	LENGTH	WEIGHT
Hydraulic power pack, 24VDC	8 3/8"	9 3/8"	37"	52 lb
Hydraulic power pack, 230VAC	19" (11")	12"	40"	100 lb
Standpipe assembly	132" max. O/A	8 5/8" diameter		200 lb
Shroud and transfer collar	18"	20" diameter		20 lb
Crane assembly 12ft to 18ft Reach	20 1/2"	20" diameter base		1300 lb
		11" boom	160" retracted	
			232 3/4" extended	
Crane assembly 11ft to 16ft Reach			149" retracted	1200 lb
			208 3/4" extended	
Crane assembly 13ft to 20ft Reach			172 1/2" retracted	1400 lb
			256 1/2" extended	
Control cable			20'	
Shipping Crate				150 lb

2 Year Platinum Warranty

Steelhead Marine Ltd. (“SML”) warrants to the original end-user (the “Buyer”) only that the “equipment” and its components are free from defective materials and workmanship for a period of two years from the date of purchase by the Buyer when purchased from SML. In the case of a new vessel, from the commissioning date of the vessel, or 1 year from the date the equipment leaves SML possession (whichever is less).

This Limited Warranty covers the cost of shop labor and materials when the defective equipment or its component(s) are delivered to SML.

Examination of the Crane: The Buyer (or representative) must examine the Crane upon delivery, and must report all defects to SML within ten (10) days of said delivery, failing which it shall be conclusively agreed between SML and the Buyer that the Crane has been delivered as specified in the contract. The Buyer shall report all visible shipping damage to the delivering shipping agent forthwith upon delivery. Failure to report shipping damage as provided above shall result in any and all shipping damage repair costs becoming the responsibility of the Buyer without recourse to SML or the shipping agent.

Making a Warranty Claim: The Buyer shall establish its warranty claim by delivering to SML, within the period of this Limited Warranty, a statement in clear and concise terms, setting forth the basis of the warranty claim together with proof of purchase, the make and model of the equipment, the date on which the equipment was installed, the name and return address of the party making the claim, and the name of the person or company installing the equipment.

Upon receipt of a valid warranty claim, SML reserves the right to either repair or replace the equipment or its components on board the vessel upon which it is installed, or require the Buyer to return the defective equipment or component(s) to SML transportation prepaid.

This Limited Warranty shall include the cost of materials and labor for the repair or replacement of the equipment or its components. This Limited Warranty also covers the equipment or its components to be repaired or replaced on board the vessel upon which it is installed, however, all expenses associated with transportation of product(s), transportation of field service technician(s), and all in-the-field collateral support (equipment service, welding service, painting service) are the Buyer’s responsibility.

Repaired or replaced products are warranted for the remaining portion of this original Limited warranty period as outlined above.

Exclusions: This Limited Warranty shall not be effective and shall be void, if the equipment or its components are:

- (i) Not installed or used under normal conditions and as recommended by SML;
- (ii) Subjected to abuse, neglect, or carelessness;
- (iii) Altered or repaired by anyone not authorized by Steelhead during the term of this Limited warranty;
- (iv) Subjected to lift weight in excess of rated capacity.; or
- (v) Subjected to persons being the load or part of the load during operation of the equipment.

This Limited Warranty does not cover, and SML is in no way responsible for any supporting or structural elements of the vessel upon which the Crane is installed, or any hoses, hydraulic fluids, filters, paint, or anodized finishes not supplied by SML.



Except as expressly provided in this Limited Warranty, SML is not responsible for the proper installation of the equipment or its supporting elements. It is the responsibility of the Buyer to ensure that the supporting and structural elements, and the equipment's connection thereto, are properly engineered and can withstand the loads of the equipment while in operation. The Buyer shall periodically inspect all structural and supporting elements of the vessel and equipment, all hoses and hydraulic assemblies for signs of wear, corrosion, and/or visible deterioration. The Buyer shall cease operation of the equipment at the first indication of deterioration.

This Limited Warranty shall not be valid except when delivered by an authorized representative of SML or installing shipyard, and the Buyer shall not be entitled to rely on any other representations or warranties, whether oral or written, except as provided in this limited warranty.

THIS LIMITED WARRANTY IS IN LIEU OF ALL OTHER EXPRESS OR IMPLIED WARRANTIES. ANY WARRANTY IMPLIED BY STATUTE AND NOT EXCLUDED HEREIN, INCLUDING WARRANTIES OF MERCHANTABILITY OR FITNESS FOR A PARTICULAR PURPOSE, IS IN EFFECT ONLY DURING THE DURATION OF THE EXPRESS WARRANTY SET FORTH HEREIN.

This warranty gives the Buyer specific legal rights, and the Buyer may also have other rights which may vary from country to country or state to state. This warranty shall be construed pursuant to the laws of the Province of British Columbia.

Contact Information

Steelhead Marine Service Representatives

For distribution enquiries, please
contact **Jake Burns**

Worldwide / Canada / USA

Jake Burns – Steelhead Marine Ltd.

5367 271st Street, Unit #2
Langley, BC V4W 3Y7
Canada

Tel: (604) 607-0091
Toll Free: 1-800-770-0455 (in North America)
Cell: (604) 855 5822
Fax: (604) 607-0092
Email: jake@steelheadmarine.net
Web: www.advancedmarinetechnologies.com

California

Revolution Marine Outfitting

2390 Shelter Island Drive, #217
San Diego, CA 92106
USA

Tel: 619-403-1148
Email: revolutionmarineoutfitting@yahoo.com

Florida

Bullhead Marine Sales, Service & Installation

10 SW 23rd Street
Fort Lauderdale, FL 33315
USA

Tel: (772) 812-8303
Fax: (954) 524-5118
Email: bullheadmarine@gmail.com

Sterling Marine

3700 Hacienda Blvd, Suite F
Fort Lauderdale FL 33314
USA

Tel: (954) 584-3039
Tel: (954) 584-9898
Email: operations@sterlingmarine.com
Web: www.sterlingmarine.com

Eastern Australia

Marine Cranes Australia Pty Ltd.

15/75 Waterways Drive
Coomera Qld 4209

Tel: +61 7 5573 0888
Fax: +61 7 5665 6266
Cell: + 61 0407 757 677
Email: info@marinecranesaustralia.com.au
Web: www.marinecranesaustralia.com.au

Western Australia

Logic Cranes

66 Dowd St.
Welshpool 6106
Western Australia

Tel: +61 8 93534477
Fax: +61 8 93535433
Email: logiccranes@wanet.com.au
Web: www.logiccranes.com.au

Germany

Sailtec GmbH

Hasselbinnen 28
D-22869 Schenefeld
Germany

Tel: +49-(0)40-8229940
Fax: +49-(0)40-8304279
Email: info@sailtec.de www.sailtec.de

Netherlands

Belship

Krommewtering 61A
3543 AM Utrecht
The Netherlands

Tel: (+31) 030 240 8040
Fax: (+31) 030 240 8041
Email Sales: j.jeltes@belship.nl
Email Service: melle@belship.nl www.belship.nl

New Zealand

Lusty & Blundell Ltd.

38 Tawa Drive Albany
Private Bag Takapuna
Auckland 9 New Zealand

Tel: 09 415 8303
Fax: 09 415 8304
Email: grantm@lusty-blundell.co.nz
Web: www.lusty-blundell.co.nz

So-Pac Marine

PO Box 303-180 North Harbor
North Shore 0751
New Zealand

Tel: +64 (9) 448 5900
Email: mhall@sopac.co.nz
Web: www.sopac.co.nz

Turkey

Ova Marine Ltd.

Setur Yalova Marina
Cekek Yeri, No: 45
Yalova, Istanbul

Tel: +90 226 813 0015
Fax: +90 226 813 0025
Email: info@ovamarine.com
Web: www.ovamarine.com

United Kingdom

MDS Marine Ltd.

Hamble Point Marina
Workshop 7, Firefly Road School Lane
Hamble, Southampton SO 31 4NB
United Kingdom

Tel: 44 (0) 2380 457656
Mobile: 44 (0) 7712 645551
Email: info@mdsmarine.co.uk www.mdsmarine.co.uk

Appendix – Wiring Diagram

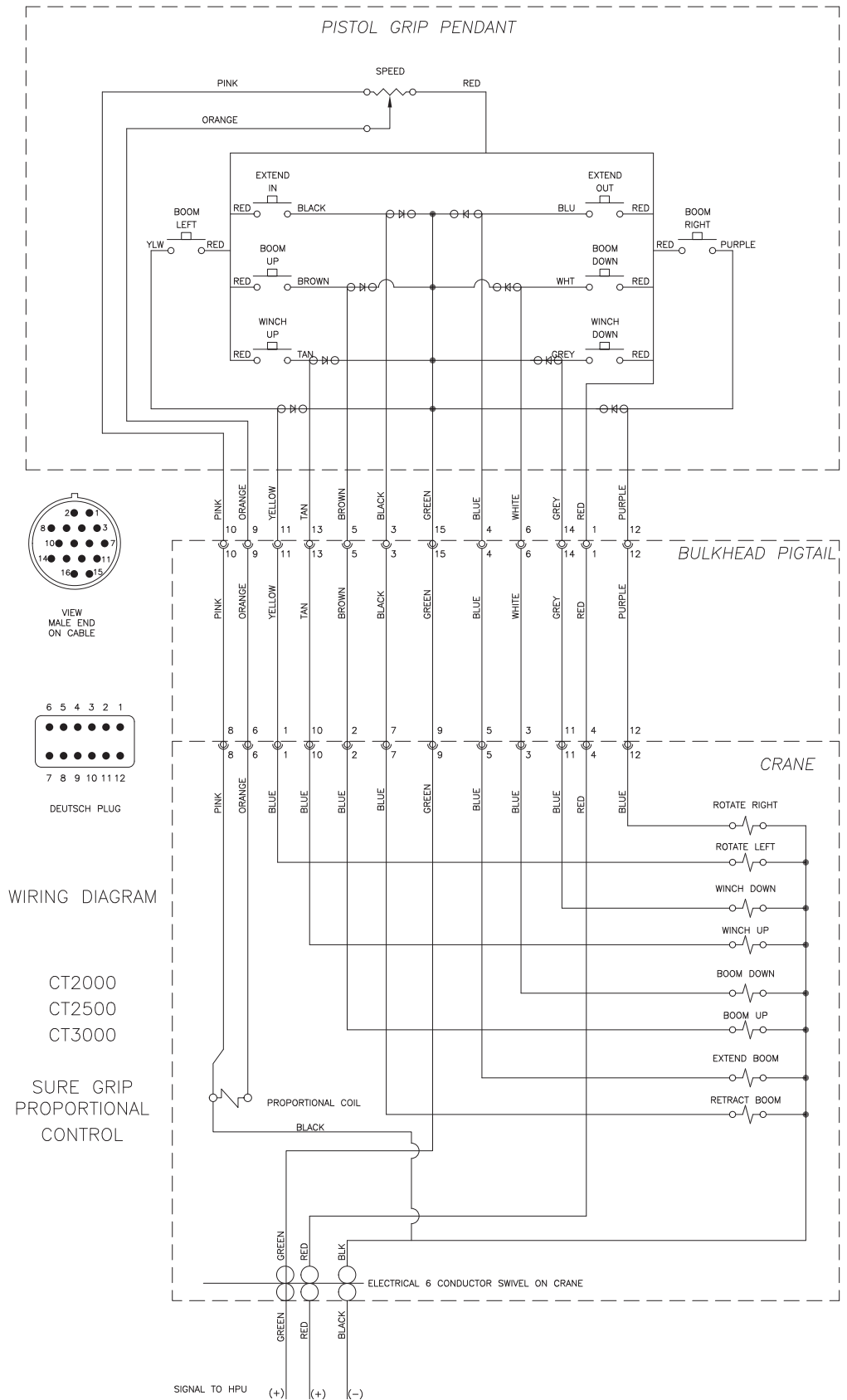

Appendix – Manifold

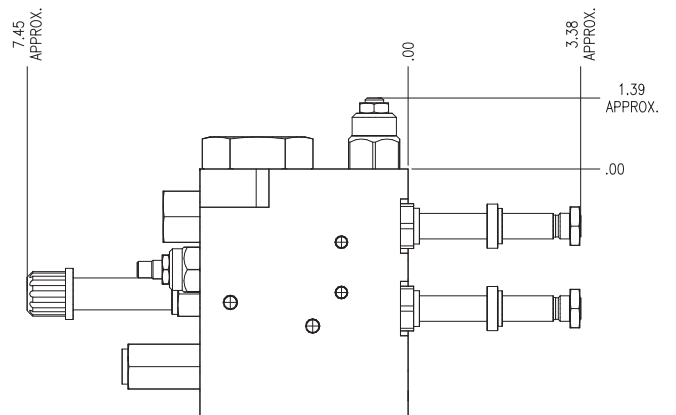
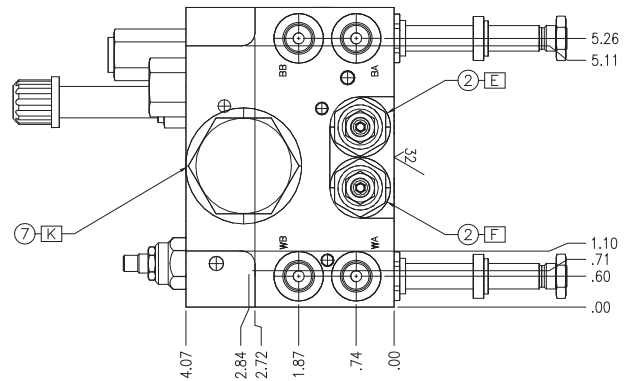
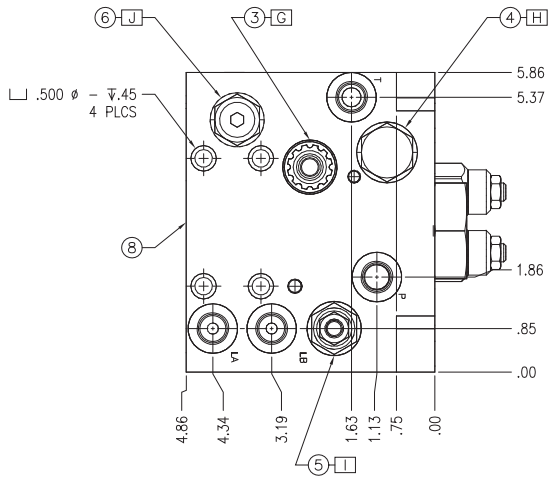
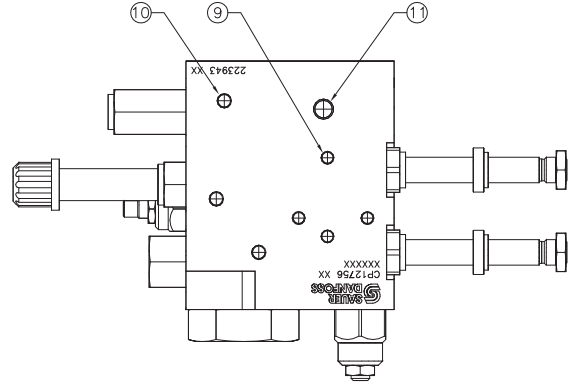
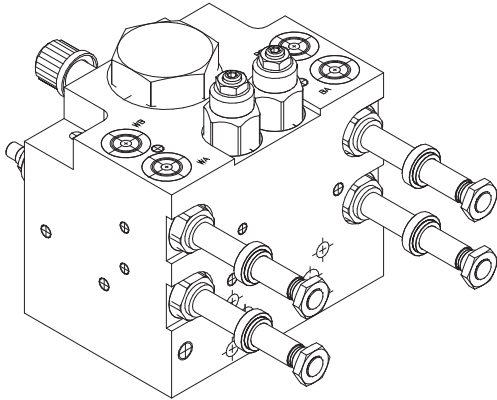

NOTES:

1. ALL PORTS SIZES ARE #6 SAE.
2. STAMP PART NO., REV# & DATE UNDER LOGO.
3. INSTALL EXPANSION PLUGS PER PC26.
4. INSTALL CARTRIDGES PER PC11.
5. TEST PER TEST PROCEDURE CP12756.

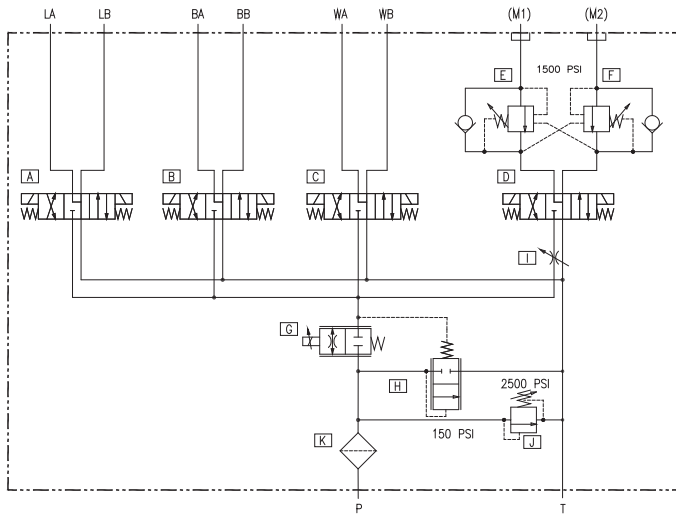

REVISIONS				
SIDE	DESCRIPTION	DATE	ECN	REV
	ITEM 3, CP518-P1-U-0-4-000-0 WAS CP518-P1-U-0-8-0-000	04-01-04	684	P1

THIS PROPOSAL DRAWING APPROVED
FOR PROTOTYPE RELEASE

BY _____

TITLE _____

DATE _____

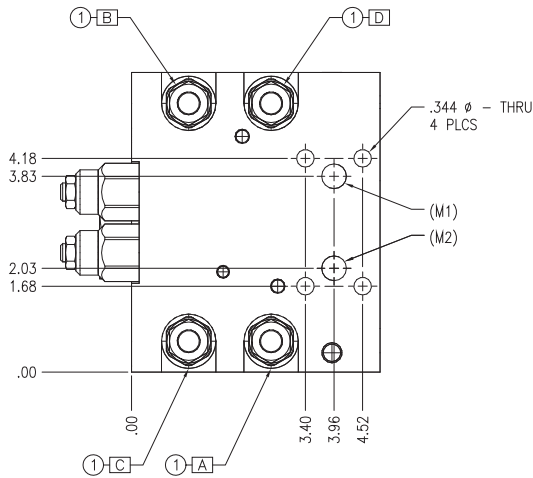

SIMILAR TO CP12681

11	4	322804	10MM STAINLESS STEEL EXP. PLUG
10	11	321451	.281# STAINLESS STEEL EXP. PLUG
9	15	321450	.250# STAINLESS STEEL EXP. PLUG
8	1	223943	BODY
[K]	7	1	CPF20-3-B-0-PN-10 20-3 CAVITY FILTER
[J]	6	1	CP208-1-B-0-A-250 RELIEF VALVE
[I]	5	1	CP618-A05-B-0-E NEEDLE VALVE
[H]	4	1	CP700-1L-B-0-150 DIFFERENTIAL SENSING VALVE
[G]	3	1	CP518-P1-U-0-4-000-0 PROPORTIONAL VALVE
[E][F]	2	2	CP440-A11-B-0-E-B-150-4.5-015 COUNTER BALANCE VALVE
[A][B][C][D]	1	4	CP538-3P-U-0-5-000-0 SOLENOID VALVE
CARTRIDGE CODE	ITEM	QTY	P/N: 139968 DESCRIPTION
MATERIAL		BODY: ALUMINUM 6061-T6 5 X 6 X 4.070	
HEAT TREATMENT			
SURFACE TREATMENT		BODY: BLACK ANODIZE	
UNLESS OTHERWISE SPECIFIED		DO NOT SCALE DRAWING	
FINISH 125/		ANGLES ± .2°	
2 PLACE DIM: .02		3 PLACE DIM: ± .010	
REMOVE ALL BURRS			
DR LUTZ		SCALE 5:8	HP NO. DATE 02-17-04
TITLE PROP. MOTOR MANIFOLD		SIZE D	PART NO. CP12756
USED ON AKTIV		REV P1	PAGE 1 OF 1



Appendix - HPU

24V DC HIGH OUTPUT HPU MOUNTED TO DRIP TRAY

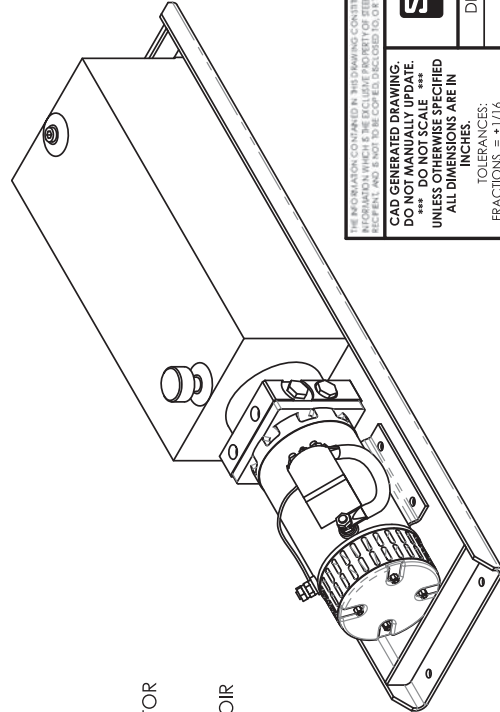
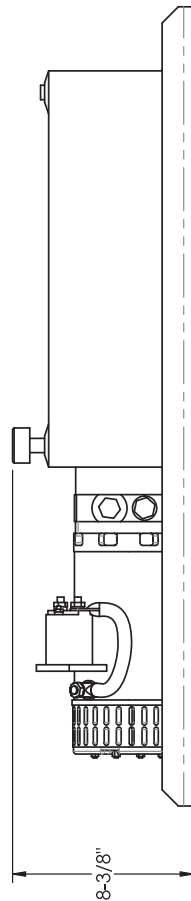
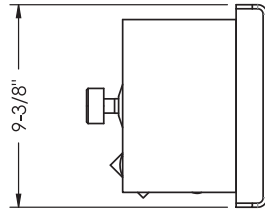
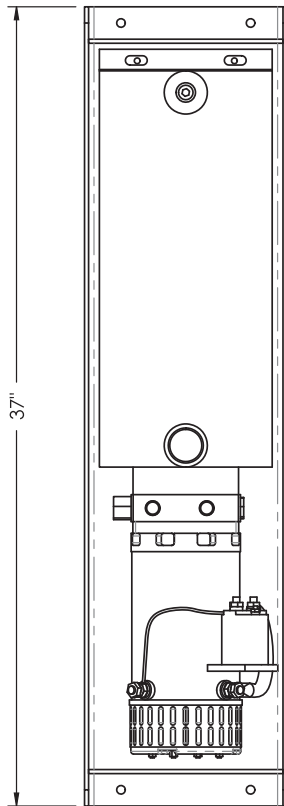

SPECIFICATIONS:

- 24V DC 1.25A STANDARD DUTY MOTOR
- 0.122 CU.IN./REV. PUMP
- 1.05 GPM @ 2000PSI
- 2500 PSI PRESSURE RELIEF
- 4 GALLON CAPACITY STEEL RESERVOIR
- HORIZONTAL PLUMBING KIT

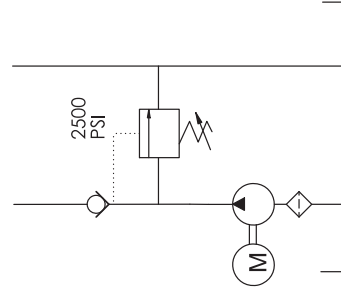

HYDRAULIC SCHEMATIC

THIS DRAWING IS THE PROPERTY OF STEELHEAD MARINE TECHNOLOGIES, INC. IT IS TO BE USED ONLY FOR THE PROJECT AND SITE SPECIFICALLY IDENTIFIED HEREIN. IT IS NOT TO BE REPRODUCED, COPIED, OR TRANSMITTED IN ANY FORM OR BY ANY MEANS, ELECTRONIC OR MECHANICAL, INCLUDING PHOTOCOPYING, RECORDING, OR BY ANY INFORMATION STORAGE AND RETRIEVAL SYSTEM, WITHOUT THE WRITTEN PERMISSION OF STEELHEAD MARINE TECHNOLOGIES, INC. ALL RIGHTS ARE RESERVED.

STEELHEAD MARINE
 2, 5897 271 Street, Langley, B.C. Canada
 7-494-4766
 Web: www.steelheadmarine.net
 E-mail: sales@advancedmarine technologies.com

**CAD GENERATED DRAWING.
 DO NOT MANUALLY UPDATE.
 *** DO NOT SCALE ***
 UNLESS OTHERWISE SPECIFIED
 ALL DIMENSIONS ARE IN
 INCHES.**

TOLERANCES:
 FRACTIONS = ±1/16
 DECIMALS = ±0.005
 ANGLES = ±1.0

DRAWN:	G.R.
DATE:	03/27/2014
CHECKED:	
APPROVED:	
SCALE:	1:8

**24V HIGH OUTPUT HPU
 MOUNTED TO DRIP TRAY
 PROJECT: SM/CT2500**

DWG. NO.: SHAR-UT050
 SHEET: 1 OF 1
 REV.:

3rd ANGLE PROJ.

Appendix – Exploded View

ITEM NO.	UPON RECEIPT	PART NUMBER	DESCRIPTION	MATERIAL	GRADE
1	1	CT2500-SM2500	TRUCK ASSY.	ALUMINUM	
2	1	CT25-AL-A0100	BOOM BODY ASSEMBLY	STEEL & STAINLESS STEEL (SEE BOM)	
3	1	CT25-0100	LUFFING CYLINDER ASSY - CT2500		
4	1	CT25-AL-X0100	BOOM EXTENSION CYL. ASSY.		
5	1	CT25-AL-0100	BOOM EXTENSION CYL. ASSY.		
6	1	CT25-AL-W0100	LINEAR WINCH	SEE BOM	
7	2	CT25-AL-W0111	LW MOUNT BAR	ASTM A240 (2205) SS	
8	1	SHAR-R0500	ROPE	WOVEN NYLON	
9	1	SHAR-R0500	HOOK WEIGHT ASSEMBLY		
10	1	LUFF-Boom Pin Assembly			
11	2	FAST-HR0100	SCREW, FLAT HEAD, ALLEN, 5/16"x1"		

CAD GENERATED DRAWING. DO NOT MANUALLY UPDATE.
 ALL DIMENSIONS ARE IN INCHES.
 TOLERANCES:
 FRACTIONS = ±1/16
 0.00 = ±0.030
 0.00 = ±0.010
 0.00 = ±0.005
 ANGLES = ±1.0

SM STEELHEAD MARINE
 Unit# 2 - 5367 271 Street, Langley, B.C. Canada
 Tel: 604-607-0091 Fax: 604-607-0092
 Web: www.steelheadmarine.net
 Email: sales@steelheadmarine.net

EXPLODED VIEW
 CT2500
 PROJECT: CT2500
 DWG. NO.: CT2500-AL Expl
 SCALE: 1:16
 SHEET: 1 OF 1



Contact

www.SteelheadMarine.net

Email: info@SteelheadMarine.net • 604-607-0091 • Toll Free: 1-800-770-0455
5367 271st Street Langley, British Columbia Canada V4W 3Y7