



CT3500
SWL : 12ft 6in - 20ft
3500lbs

*Owner's Operation, Installation &
Maintenance Manual*

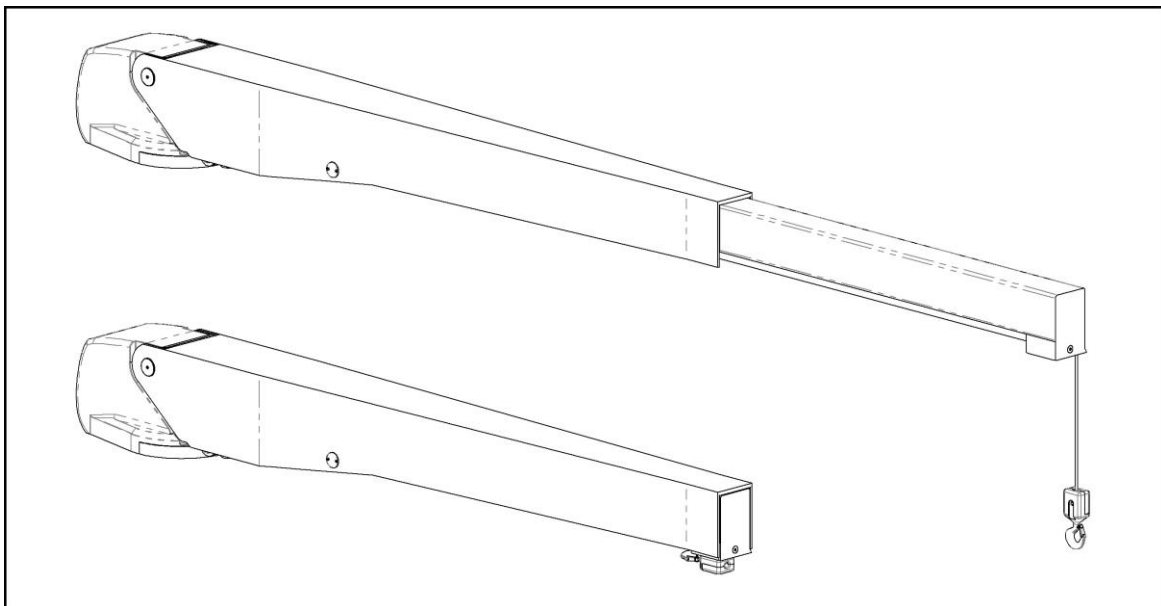



Table of Contents

Yacht Crane Assembly Drawing	4
Spacer Plate Mounting Assembly Drawing	5
Required Equipment & Tools	6
Supplied Equipment List.....	6
Hydraulic & Electrical Connections	7
Completing & Testing Installation	8
Operating Instructions	9
Warning review before operation.....	9
Operating Instructions	9
Pendant Control	11
Reach Table and Crane Storage	12
Linear Winch Assembly and LED Light	13
Crane Maintenance	15
Hydraulic System Components	16
Troubleshooting	17
Specifications	18
Electrical System.....	18
Equipment Dimensions.....	18
Warranty	19
Appendix	
Hydraulic Schematic	APPENDIX A
Crane Electrical Schematic	APPENDIX B
Hydraulic Manifold Diagram	APPENDIX C

Notice to Boat Manufacturer or Installer

Throughout this publication, Warnings and Cautions accompanied by the International Hazard Symbol  is used to alert the manufacturer or installer to special instructions concerning a particular service or operation that may be hazardous if performed incorrectly or carelessly.

Observe Them Carefully! These “safety alerts” alone, cannot eliminate the hazards that they signal. Strict compliance to these special instructions when performing the installation and maintenance plus “common sense” operation are major accident prevention measures.



DANGER

Immediate hazards which WILL result in severe personal injury or death.



WARNING

Hazards or unsafe practices, which COULD result in severe personal injury or death.



CAUTION

Hazards or unsafe practices, which COULD result in minor injury or product or property damage.

NOTICE

Information, which is important to proper installation Or maintenance but is not hazard-related.

Yacht Crane General Assembly Drawing

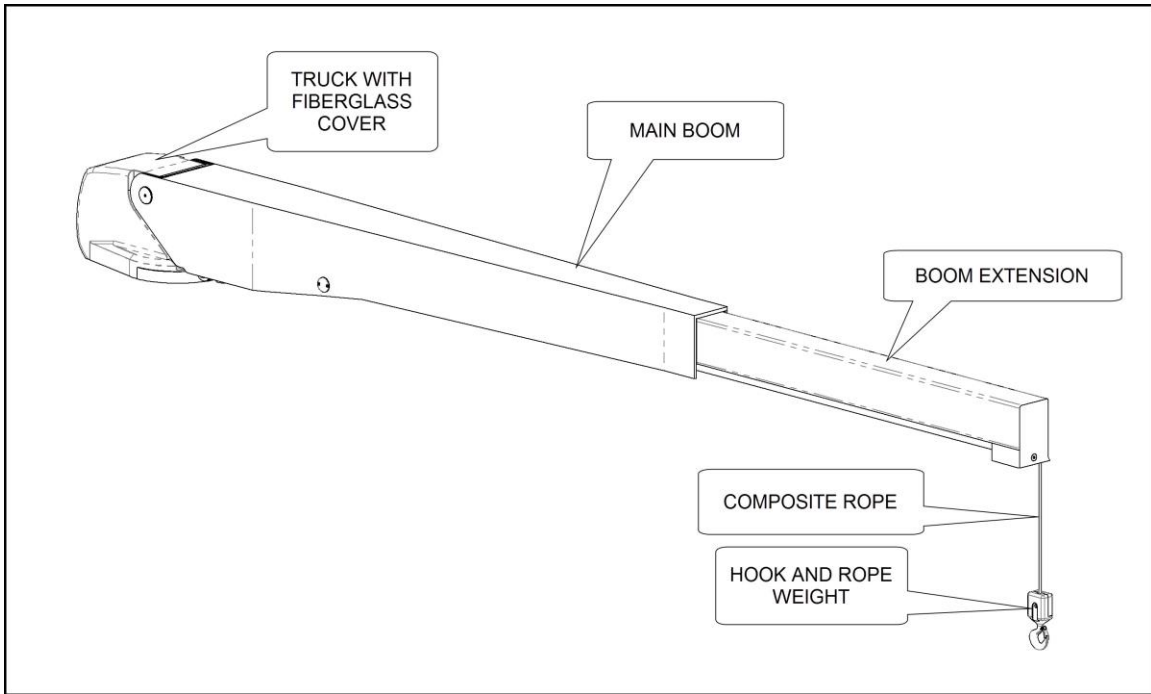

Crane - Exterior Components

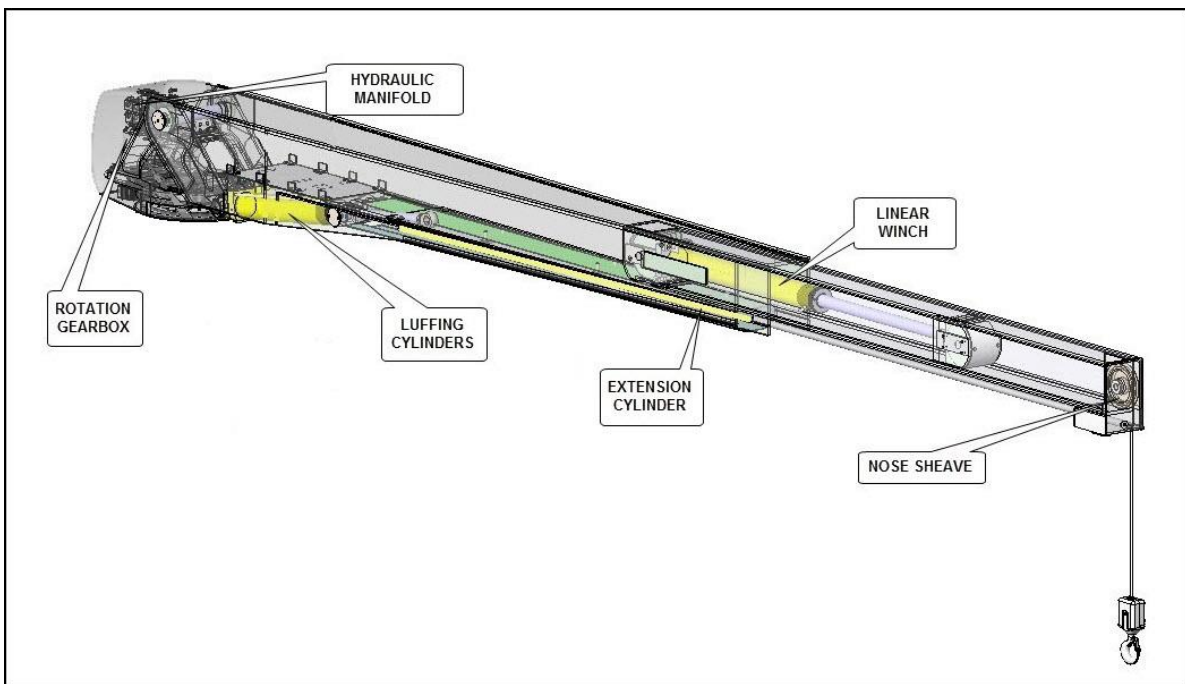

Crane – Interior Components

Spacer Plate Mounting Assembly

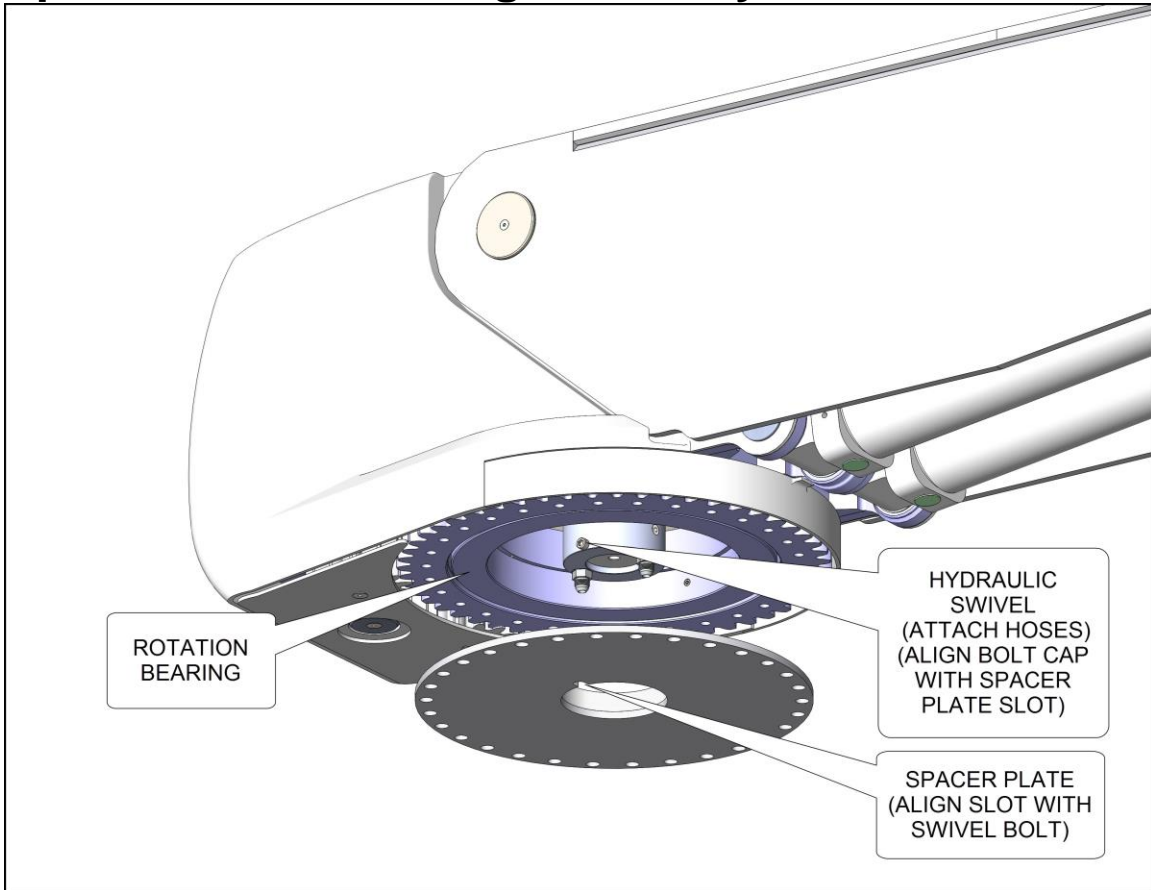

Required Equipment & Tools

This section describes the equipment and tools needed or recommended for the yacht crane installation.

Supplied Equipment List

Your yacht crane comes with the following standard equipment:

Crane assembly, complete with:

- bearing assembly installed
- hydraulic and electrical system installed
- composite rope, hook and weight assembly installed
- (30) 5/8-11 UNC x 2 1/2" 316 Stainless Steel mounting bolts and washers
- 360 degree rotary swivel c/w two male #8 MJIC connections
- 360 degree 3-contact electrical swivel
- 4 function, hand-held pendant control (wired remote control)
- Crane hydraulic control manifold (installed in crane)
- Owner's Handbook and Installation Manual

Hydraulic & Electrical Connections

The Hydraulic Swivel has one pressure line (JIC#6 connector), one return line (JIC#6 connector).

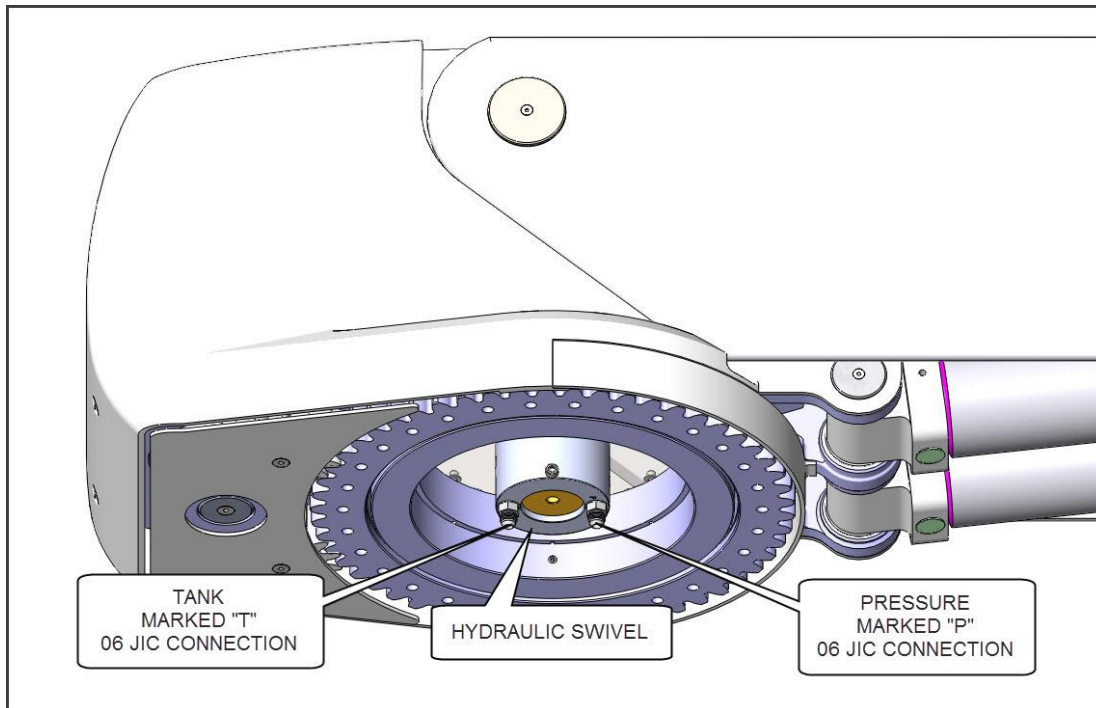

Crane Hydraulic Connections

To install the crane's hydraulic and/or electrical connections:

1. Lead two #8 hydraulic lines from hydraulic power unit to top of standpipe mounting plate. Add 12" extra length for connection.
2. Lead 3/16 electrical wire from power unit connection points to crane mounting plate. Again, add 12" extra length for connections.
3. Make hydraulic connections by connecting the (2) hydraulic lines on the hydraulic swivel.

Pressure – #8 JIC connector

Return – #8 JIC connector

-
4. Complete electrical connections, and use heat shrink to seal connections from corrosion.
 5. Complete hydraulic and electrical connections at ship.

Completing & Testing Installation

To complete and test the installation of the crane:

1. Lower crane onto mounting plate, ensuring that the hydraulic swivel fits correctly into the retaining notch in center of mounting plate.
2. Install mounting bolts and torque to recommended values (*see below*).
3. Test crane as follows:
 - Turn breakers on momentarily.
 - Ensure power unit turns on.
 - Check all wiring.
 - Check hydraulic source and ensure correct pressure from pressure port.
 - Turn on control breaker.
5. When systems are confirmed correct, recheck oil level in reservoir in HPU and refill to proper level.
6. Use Tef-Gel where stainless screws contact painted surfaces to prevent paint blistering and corrosion.
7. During shipment, air may have collected in hydraulic system. To bleed, operate all boom functions through their full travel capacity 3 or 4 times, using pendant hand control. This will remove any air in the system.
8. Recheck oil level in reservoir to ensure level has been maintained.

Bolt Torque Recommendations

1. Use thread lubricant (moly disulfide grease) on threads before beginning to torque bolts.
2. Apply torque of 30 ft-lb in a cross or star pattern.
3. Apply final torque of (70-80 ft-lb) using the same order.

Operating Instructions

Warning review before operation

Misuse of the crane may result in injury or death.

Always follow carefully these safety cautions:

- Never load the crane system beyond its capacity
- Be sure the area around and under the tender is clear of people and obstacles before lowering, including lower decks and water level.
- Remove all cargo and excess water from the tender before raising or lowering.
- Unless the craft is being used as a rescue boat in an emergency, ensure all passengers leave the tender before raising and lowering — the crane is not a personnel lift.
- Position the crane directly over the load when operating — the crane is designed for vertical hoisting only.
- Unless the craft is being used as a rescue boat in an emergency, do not launch or retrieve the tender in rough sea conditions, or while underway.
- Be aware that yachts tend to list when launching a tender. Use caution when rotating a load.
- Do not allow children to operate the crane.
- Keep hands away from all moving parts.
- Turn the crane's power supply off when not in use.
- Detach crane from tender and retract boom to stow.



REVIEW BEFORE OPERATING

NOTICE

A release hook is permanently attached to the rescue boat. Maintenance of the release hook is carried out while the rescue boat is in its cradle on the deck. A foul weather stop will be provided. The boom arrangement enables the rescue boat, attached to the foul weather stops, to be lifted out of the water and onto the deck, without the need for hanging-off arrangements.

NOTICE

Safety devices are normally fitted which will automatically cut off the power before the davit reaches its travel limits with respect to hoisting, luffing and slewing in order to prevent over stressing of the fall or davit. However, for this specific model, the hydraulics is designed to prevent such over stressing.

Operating Instructions

1. Turn on hydraulic supply by switching on the breaker to supply power to the hydraulic power unit.
2. Attach the tender's lifting bridle to the weighted hook. Using the crane's controls, position the lifting bridle to enable attachment to the tender.
3. Raise the lifting bridle just enough to remove any slack from the cables. Check all attachments to the tender.

-
4. Remove the tender's attachments to the deck, and ensure the tender's drain plug is installed.
 5. Attach the handling lines to the bow and stern of the tender.
 6. Raise the tender high enough to clear all deck obstructions and railings.
 7. Rotate the load outboard, controlling the tender position with bow and stern lines.
 8. Lower the load to the water. Pay out enough cable so that the tender does not load the cable and crane as it rides waves or swells.
 9. Using the load-handling lines, pull the tender to a point near the vessel where it may be boarded. Disconnect the lifting bridle from the tender.
 10. Secure the weighted hook so that it does not swing into the side of the vessel.

Pendant Control

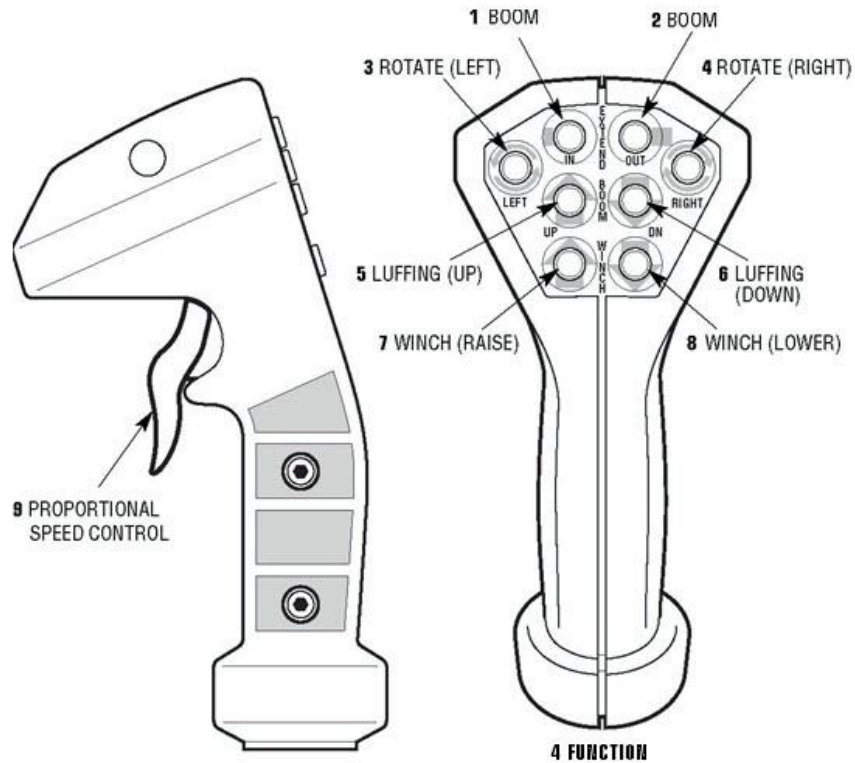

The Pendant Control gets connected to the waterproof connectors found on the crane's fiberglass truck cover. The pendant control is proportional, therefore the speed of operation relates to the amount of trigger force.

SEE APPENDIX FOR ELECTONIC SCHEMATIC DIAGRAMS.

Crane Capacity: SWL: 3500lbs

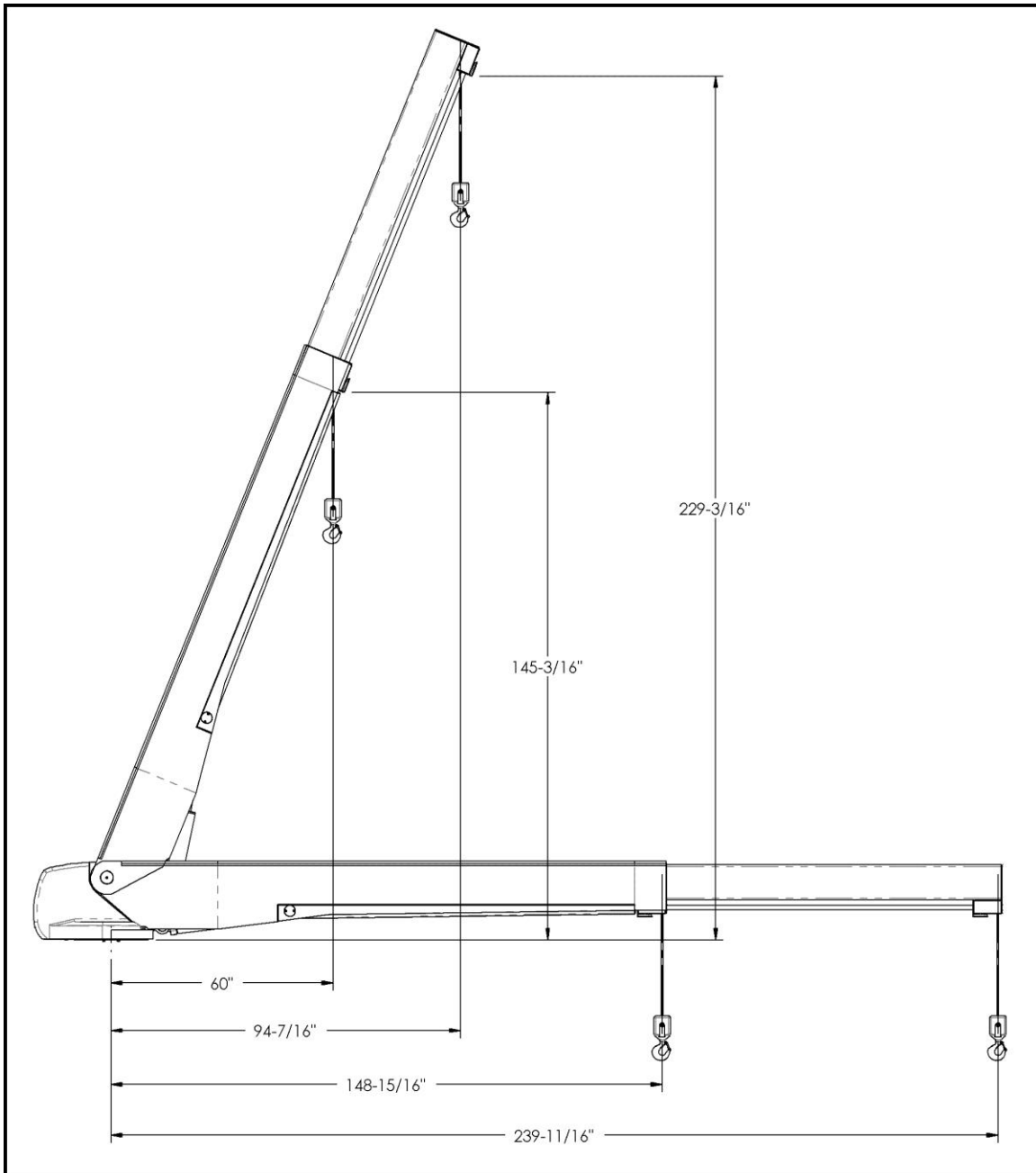

Reach Table

Crane Storage

To properly store the crane after use:

1. Fully retract the boom.
2. Rotate Crane to desired position.
3. Luff crane to horizontal position.
4. Disconnect Control and store in dry heated area of the vessel.

Linear Winch General Assembly Removal

Linear Winch Spare Parts

The Linear Winch comes supplied with dia. 1/2" AMSTEEL - BLUE rope.
Only certified **AMSTEEL - BLUE, diameter 1/2"** can be used as a replacement.

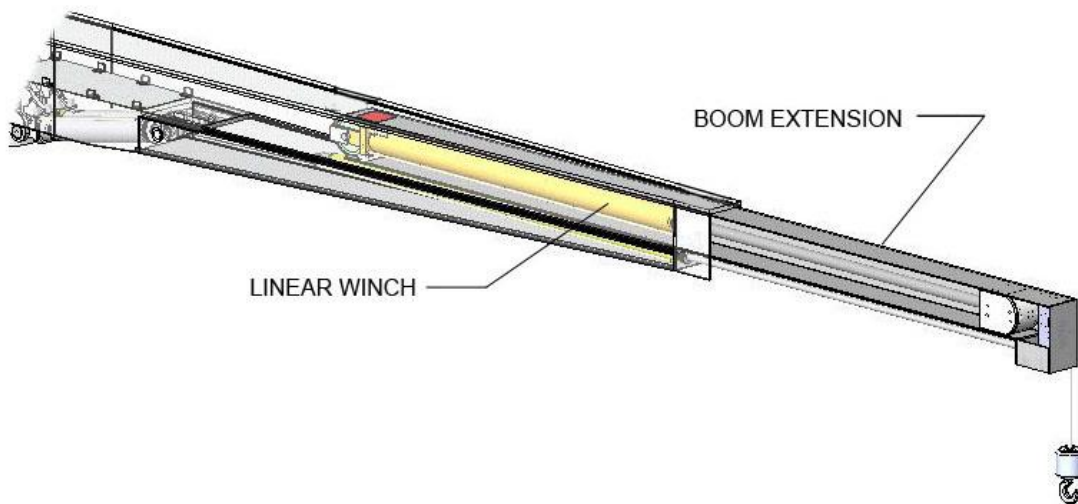

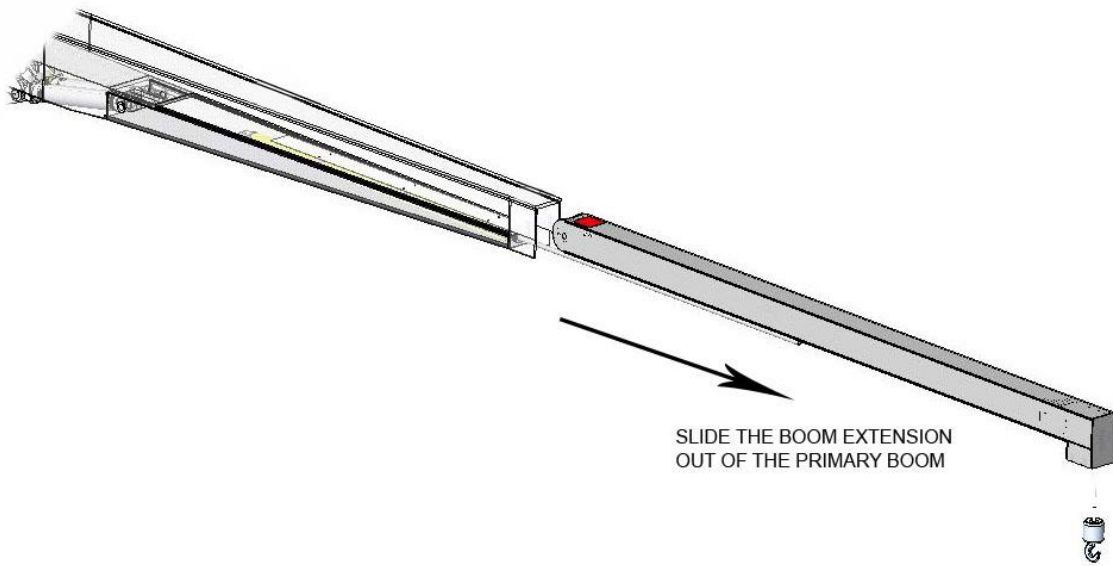
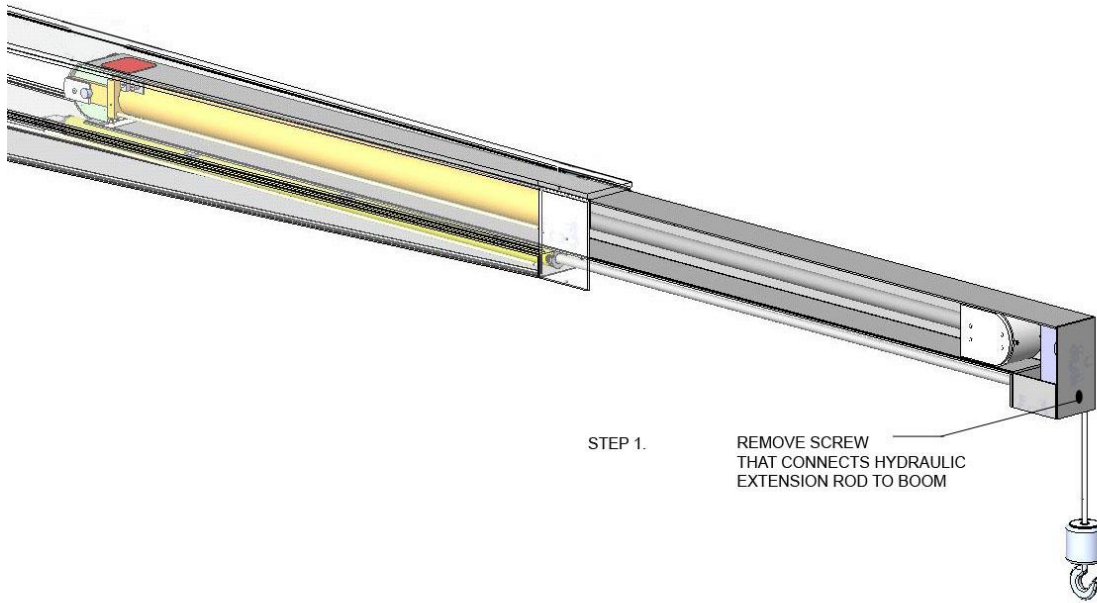

STEP 3.

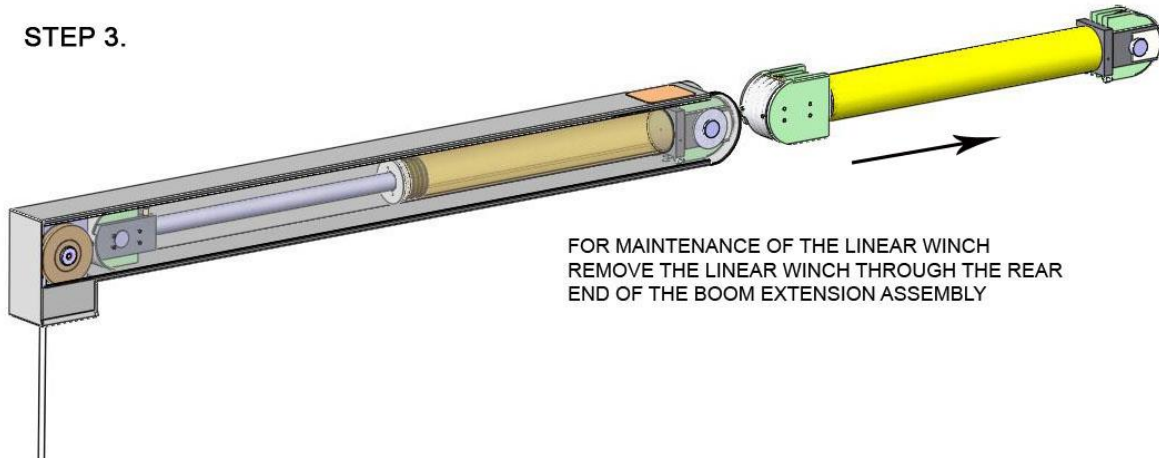

FOR MAINTENANCE OF THE LINEAR WINCH REMOVE THE LINEAR WINCH THROUGH THE REAR END OF THE BOOM EXTENSION ASSEMBLY

Crane Maintenance

Maintenance Schedule

	Monthly	3 Months	Annually	As required
Inspect main hoist cable. Replace upon first sign of frays, fishhooks, flattening, kinks, corrosion, audible pinging or snapping sounds.		✓		
Replace hoist cable and return to Steelhead Marine.				✓
Inspect all cables and hydraulic hoses and fittings. Replace at first sign of corrosion or excessive wear.	✓			
Inspect crane and its hardware components for signs or damage or malfunctioning parts.			✓	
Touch-up any paint damage to preserve the crane's finish.				✓
Wash crane with soap and water.	✓			
When cleaning the crane, inspect for hydraulic leaks at the power unit and cylinders. Tighten the fittings as required to stop any leaks.	✓			
Inspect and lubricate the crane rotation bearings.		✓		
Inspect the sheaves.				✓
Service the hydraulic system annually or after 250 hours of use, whichever comes first.			✓	
Maintain fluid levels. Use AW-32, AW-48 or equivalent non-foaming hydraulic fluid only.				✓



WARNING

**REVIEW BEFORE
COMMENCING MAINTENANCE.**

Safety Cautions

Death, injury, or damage may result if the crane's cable is not inspected regularly, and replaced as needed.

Counter balances have been factory set for optimal performance; crane safety may be jeopardized by unauthorized adjustments.

Hydraulic System Components

SEE APPENDIX FOR HYDRAULIC SCHEMATIC DIAGRAMS.

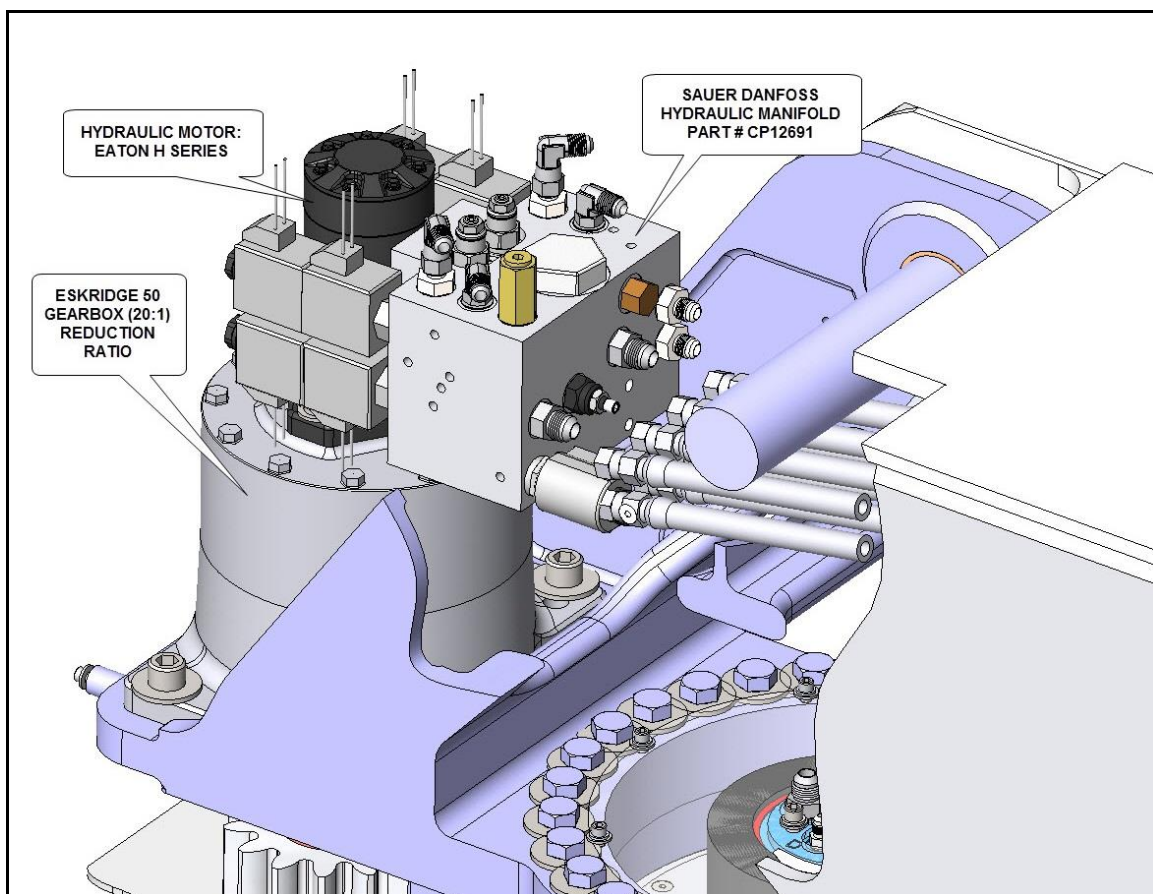

Troubleshooting

PROBLEM	PROBABLE CAUSE	SOLUTION
Crane will not luff	No power (control)	Turn control breaker on
Crane will not rotate	No power (power pack) Breaker (fuse) blown Pendant control connection (loose) Low hydraulic oil	Turn control breaker or reset if required Check breaker Check all connections (ship side) Check for leaks and oil level top up if necessary
Linear winch does not raise or lower	Wrong switch used Tender not disconnected Overload on crane Hook travel exceeded Cable jammed inside linear winch	See page 14 Release tender tie downs Check tender for equipment and excess water Max. travel of 30'. Hook retracts to underside of outer sheave. Call Dealer for service or instructions
Winch does not hold weight	Winch does not hold weight	Call Dealer for service or instructions
Boom settles under load	Boom settles under load	Call Dealer for service or instructions
Boom rotates when not under power	Boom rotates when not under power	Call Dealer for service or instructions

Specifications

Electrical System

- The control system: 24V
- Hand held pendant with 25ft. cord provides 4-function control and connects to crane body with waterproof plug and cap. Low voltage output automatically starts hydraulic power pack or ship's hydraulics.

Hydraulic System

- Operational pressure is 2500 psi.
- Flow Rate: 4 GPM.
- **Slewing** - rotation is powered by a hydraulic motor driving a planetary gearbox driving pinion gears on the main bearing.
- **Luffing** - boom elevation, a counterbalance valve installed in the cylinder locks boom elevation at any angle between 0 and 65 degrees
Counterbalance: **SUN CBCG-LDN**
- **Winch** - 8 to 1 linear winch provides quiet lowering and hoisting
Counterbalance: **SUN CBCG-LDN**
- **Extension** – extending the boom, a counterbalance valve is installed in an external manifold at the back of the cylinder. Counterbalance: **SUN CBCG-LDN**

Fittings, Hardware, and Cables

- The hook and weight are an integrated unit. They are constructed of 2205 Duplex stainless steel.
- The hoist rope is made of 12mm (1/2") Amsteel composite (10:1 safety factor)

Equipment Dimensions

COMPONENT	Height from Base	Width	Length	Weight
Crane Assembly	56" / 1422mm	27.5" / 700mm dia. base	20ft	3275 lbs (1488) kg

Warranty

Steelhead Marine Ltd. (“Steelhead”) warrants to the original end-user (the “Buyer”) only that the yacht crane (the “Crane”) and its components are free from defective materials and workmanship for a period of two (2) years from the date of purchase by the Buyer when purchased from Steelhead or an authorized dealer of Steelhead. In the case of a new vessel, the warranty is valid from the commissioning date of the vessel.

This Limited Warranty covers the cost of shop labor and materials when the defective Crane or its components are delivered to Steelhead.

Examination of the Crane: The Buyer must examine the Crane upon delivery, and must report all defects to Steelhead within ten (10) days of said delivery, failing which it shall be conclusively agreed between Steelhead and the Buyer that the Crane has been delivered as specified in the contract. The Buyer shall report all visible shipping damage to the delivering shipping agent forthwith upon delivery. Failure to report shipping damage as provided above shall result in any and all shipping damage repair costs becoming the responsibility of the Buyer without recourse to Steelhead or the shipping agent.

Making a Warranty Claim: The Buyer shall establish its warranty claim by delivering to Steelhead at its Customer Service Center at #2 – 5367 271st Street, Langley, British Columbia, V4W 3Y7, within the period of this Limited Warranty, a statement in clear and concise terms setting forth the basis of the warranty claim together with proof of purchase, the make and model of the Crane, the date on which the Crane was installed, the name and return address of the party making the claim, and the name of the person or company installing the Crane. Upon receipt of a valid warranty claim, Steelhead reserves the right to either repair or replace the Crane or its components on board the vessel upon which it is installed, or require the Buyer to return the defective Crane or component(s) to Steelhead at its Customer Service Center at #2 – 5367 271st Street, Langley, British Columbia, V4W 3Y7, transportation prepaid.

This Limited Warranty shall include the cost of materials and labor for the repair or replacement of the Crane or its components at Steelhead’s Customer Service Center. This Limited Warranty also includes the Crane or its components to be repaired or replaced on board the vessel upon which it is installed, however, all expenses associated with transportation of product(s), transportation of field service technician(s), and all in-the-field collateral support (Crane service, welding service, painting service) are the Buyer’s responsibility.

Repaired or replaced products are warranted for the remaining portion of this original Limited Warranty period from the date the Crane was purchased by the Buyer.

Installation of Crane: If requested by the Buyer Steelhead will install the Crane or its components on board the vessel using its field service technicians, or at the sole discretion of Steelhead may nominate a third party installer of equivalent qualifications. Such third party installer/technician will be clearly identified in Steelhead’s commercial invoice with respect to the sale of the Crane or any of its components.

Exclusions: This Limited Warranty shall not be effective and shall be void, if the Crane or its components are (i) not installed or used under normal conditions and as recommended by Steelhead; (ii) subjected to abuse, neglect, or carelessness; (iii) altered or repaired by anyone not authorized by Steelhead during the term of this Limited Warranty; (iv) subjected to lift dead weight in excess of rated capacity.; or (v) subjected to persons being the load or part of the load during operation of the Crane.

This Limited Warranty does not cover, and Steelhead is in no way responsible for any supporting or structural elements of the vessel upon which the Crane is installed, or any hoses, hydraulic fluids, filters, paint, or anodized finishes not supplied by Steelhead Marine. Except as expressly provided in this Limited Warranty, Steelhead is not responsible for the proper installation of the Crane or its supporting elements. It is the responsibility of the Buyer to ensure that the supporting and structural elements, and the Crane's connection thereto, are properly engineered and can withstand the loads of the Crane while in operation. The Buyer shall periodically inspect all structural and supporting elements of the vessel and Crane, and all hoses and hydraulic assemblies for signs of wear, corrosion, and/or visible deterioration. The Buyer shall cease operation of the Crane at the first indication of deterioration.

This Limited Warranty shall not be valid except when delivered by an authorized representative of Steelhead or installing shipyard, and the Buyer shall not be entitled to rely on any other representations or warranties, whether oral or written, except as provided in this limited warranty.

THIS LIMITED WARRANTY IS IN LIEU OF ALL OTHER EXPRESS OR IMPLIED WARRANTIES. ANY WARRANTY IMPLIED BY STATUTE AND NOT EXCLUDED HEREIN, INCLUDING WARRANTIES OF MERCHANTABILITY OR FITNESS FOR A PARTICULAR PURPOSE, IS IN EFFECT ONLY DURING THE DURATION OF THE EXPRESS WARRANTY SET FORTH HEREIN.

This warranty gives the Buyer specific legal rights, and the Buyer may also have other rights which may vary from country to country or state to state. This warranty shall be construed pursuant to the laws of the Province of British Columbia.



**Steelhead Marine
Ltd.**

*Unit #2
5367 271st Street
Langley, British Columbia
Canada, V4W 3Y7*

Tel: 604-607-0091

Fax: 604-607-0092

Email: sales@steelheadmarine.net

www.steelheadmarine.net

*REV: A - 2014 Printed in
Canada*