

# SM Series Operating Instructions

**Misuse of the crane may result in injury or death.**

**Always follow carefully these safety cautions:**

- Do not begin hoisting until the boom has been fully extended and the stainless steel plunger locked into position.
- Never load the crane system beyond its capacity, indicated by the model name eg. SM1500, rated to lift 1500 lbs.
- Be sure the area around and under the tender is clear of people and obstacles before lowering, including lower decks and water level.
- Remove all cargo and excess water from the tender before raising or lowering.
- Ensure all passengers leave tender before raising and lowering—this crane is not a personnel lift.
- Position the crane directly over the load when operating—the crane is designed for vertical hoisting only.
- Do not launch or retrieve a tender in rough sea conditions, or while underway.
- Be aware that yachts tend to list when launching a tender. Use caution when rotating a load.
- Do not allow children to operate the crane.
- Keep hands away from all moving parts.
- Turn the crane's power supply off when not in use.
- Detach crane from tender and retract boom to stow.
- Detach pendant control when not in use.

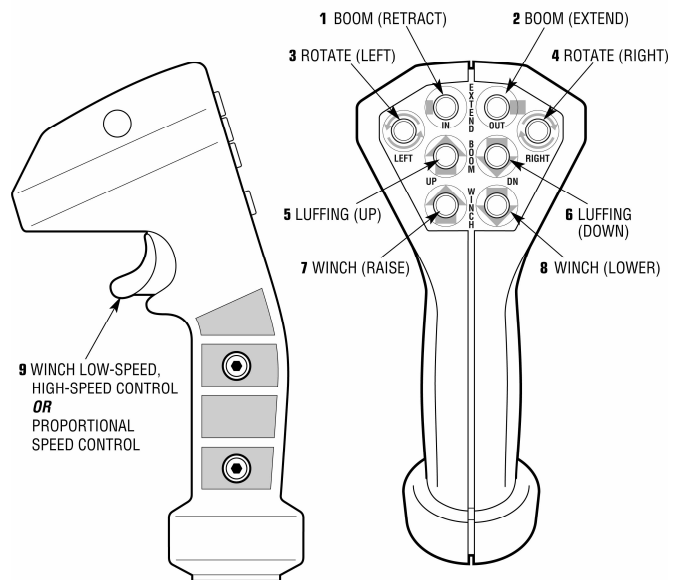

## Operating Instructions

1. Turn on hydraulic supply by:
  - activating the ship's hydraulics, OR
  - turning on the ship's main breaker to supply the crane's power pack
2. Turn on the crane's control power by flipping the 4-amp breaker.
3. Remove waterproof plug on crane body and plug in pendant control.
4. Extend boom to operational length by pressing the boom extend button on pendant control until stainless plunger snaps into locked position.
5. Disconnect weighted hook from storage eye and allow it to hang freely.
6. Attach the tender's lifting bridle to the weighted hook. Using the pendant control, position the lifting bridle to enable attachment to the tender.
7. Raise the lifting bridle just enough to remove any slack from the cables. Check all attachments to the tender.
8. Remove the tender's attachments to the deck, and ensure the tender's drain plug is installed.
9. Attach the handling lines to the bow and stern of the tender.
10. Raise the tender high enough to clear all deck obstructions and railings.
11. Rotate the load outboard, controlling the tender position with bow and stern lines.
12. Lower the load to the water. Pay out enough cable so that the tender does not load the cable and crane as it rides waves or swells.
13. Using the load-handling lines, pull the tender to a point near the vessel where it may be boarded. Disconnect the lifting bridle from the tender.
14. Secure the weighted hook so that it does not swing into the side of the vessel.