

EXTERIOR VIEW

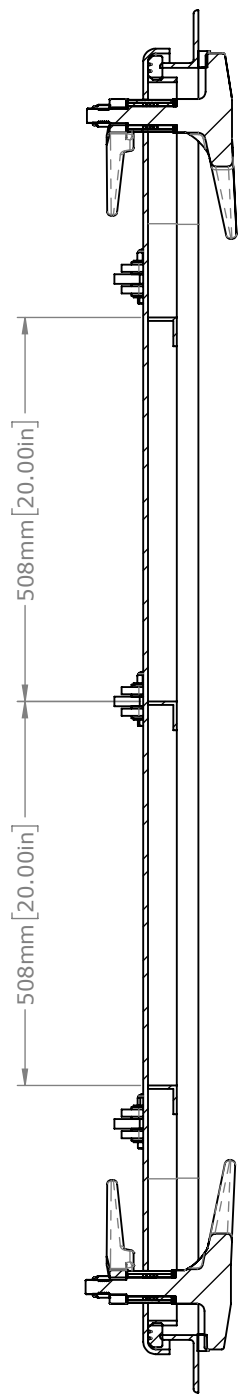

SECTION A-A

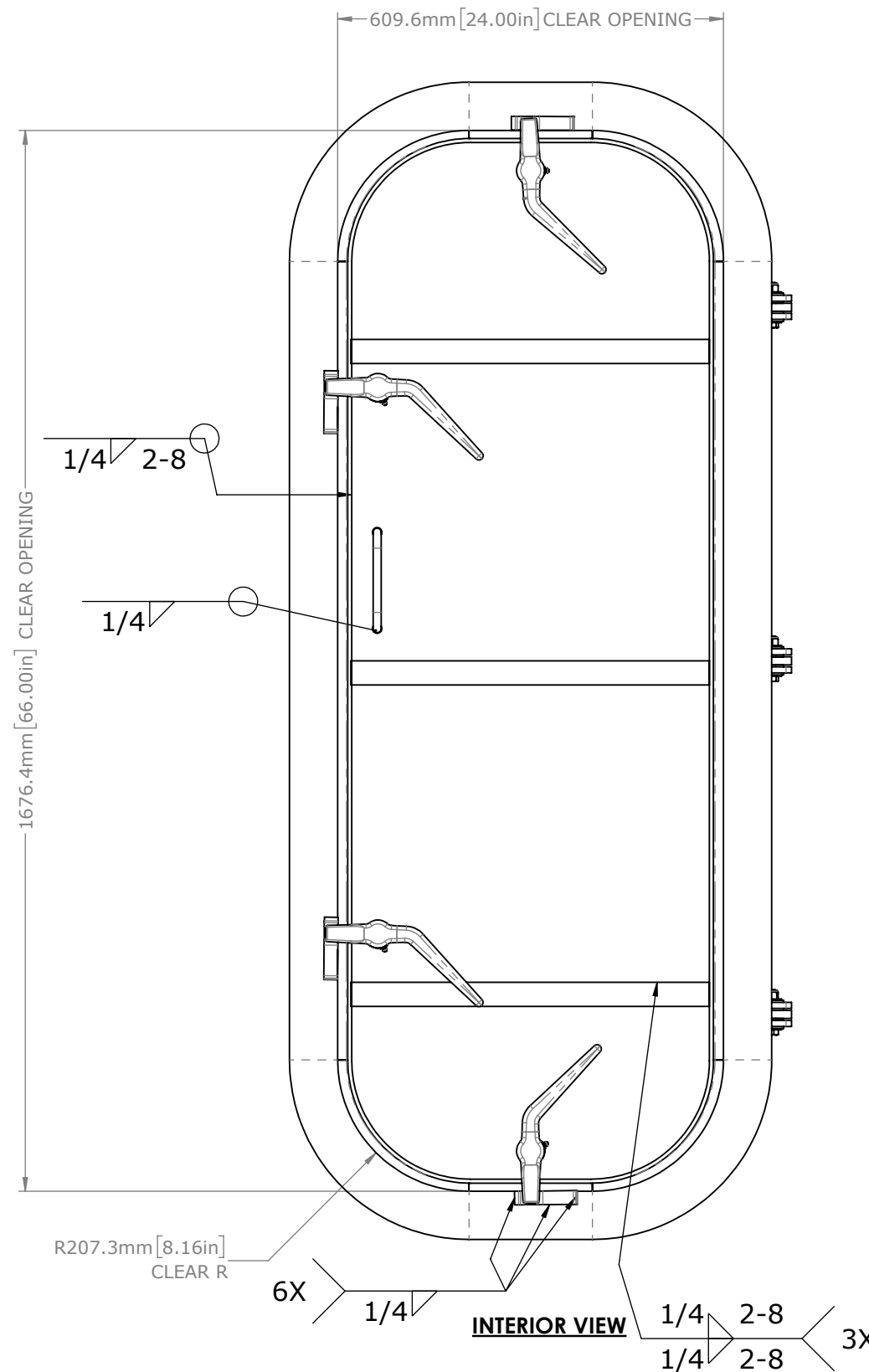

INTERIOR VIEW

REVISIONS			
REV.	DESCRIPTION	BY	DATE
00	PRODUCTION RELEASE	ZJC	21SEP16

- GENERAL NOTES**
1. REMOVE ALL BURRS AND BREAK SHARP EDGES AND CORNERS 1.0mm [.04"] MAX.
 2. WELD IN INSTALLATION
 3. WATERTIGHT CONSTRUCTION TO MEET SEALING STD II
 4. APPROX WEIGHT: 265.36kg
 5. finish: B - COMMERCIAL QUALITY

WO#

CUSTOMER APPROVAL

IMPORTANT! THIS DRAWING SUPERSEDES ALL OTHER DOCUMENTS. By signing this approval you accept and agree that the dimensions and details shown are correct and properly fit your application, regardless of any differences between this drawing and any prior contract specifications. Should you have any questions or see any errors, DO NOT SIGN THIS APPROVAL until the drawing is corrected.

SIGN	DATE			
UNLESS OTHERWISE SPECIFIED, DIMENSIONS ARE IN MILLIMETERS. TOLERANCES FOR ROUGH AND CLEAR OPENINGS ARE ±3mm (.125"). ALL OTHERS ARE:				
METRIC	X	.X	.XX	ANGLES
	±2.5	±.8	±.25	±2°
IMPERIAL	.X	.XX	.XXX	ANGLES
	±.1	±.03	±.010	±2°
BAR CODE	CAGE CODE			
	64747			



COPYRIGHT 20142015 ADVANTEC GLOBAL INNOVATIONS. ALL RIGHTS RESERVED. CONFIDENTIAL PROPERTY OF ADVANTEC GLOBAL INNOVATIONS. UNAUTHORIZED USE, REPRODUCTION OR DISTRIBUTION IS STRICTLY PROHIBITED. COPIES REMAIN THE PROPERTY OF ADVANTEC GLOBAL INNOVATIONS AND MUST BE RETURNED UPON REQUEST.

CLIENT **FME**

PROJECT TITLE

DWG TITLE					QTY
WATERTIGHT BULKHEAD DOOR					
SCALE	DRAWN	DATE	CHECKED	DATE	SIZE
1:10	ZJC	9/21/2016	DJM	9/21/2016	B
S.O. NO	DWG NO	SHEET		REV	
	1212-2466L	1 of 2		00	

ITEM	QTY	PART No.	DESCRIPTION	MATERIAL
1	1	0223-1002	DOG ASSY, INDIVIDUAL, RH	REF S.A. BOM
2	3	0223-1003	DOG ASSY, INDIVIDUAL,STEEL, LH	REF S.A. BOM
3	2	0243-2031	PULL HANDLE	BAR, STL A36 .5IN DIA ROUND (0615-9600)
4	3	0411-2027	NUT .50IN-13 SS 316 NYLOCK	SS 316/316L
5	3	0411-2029	SCREW, HH .5-13X2.5IN	SS 316/316L
6	6	0411-2693	WASHER, FLAT	SS 316/316L
7	12	0413-2114	WASHER, .521 X 1.49 X .125 NYLON	Nylon 6/10
8	1	0422-2800	PADLOCK HASP	PLATE, STL .188IN A36 (0715-2033)
9	1	0422-2801	PADLOCK HASP	PLATE, STL .188IN A36 (0715-2033)
10	3	0462-2579	BASE, HINGE	PLATE, STL .375IN A36 GRY (0715-2026)
11	3	0462-2591	HINGE,PANEL SIDE,BULKHEAD DOOR,FIXED	A36
12	2	0616-2075	MAIN FRAME	ANGLE, STL A36 HR 3X2X.313IN (0615-9534)
13	2	0616-2077	GASKET RETAINER/STIFFENER	BAR, STL A36 HR .25X1.5IN (0615-9598)
14	3	0616-2101	STIFFENER	ANGLE, STL A36 HR 1.5X1.5X.25IN (0615-9503)
15	1	0716-2066	SKIN, EXT STL A36 .25 THICK LH 2466 CO	PLATE, STL .25IN ABS A36 (0715-2020)
16	1	1212-2466L-203	GASKET	25 DURO NEOPRENE (0631-9854)

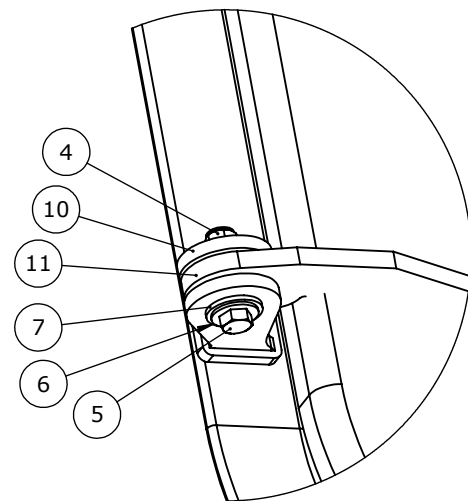

DETAIL J
SCALE 1 : 5

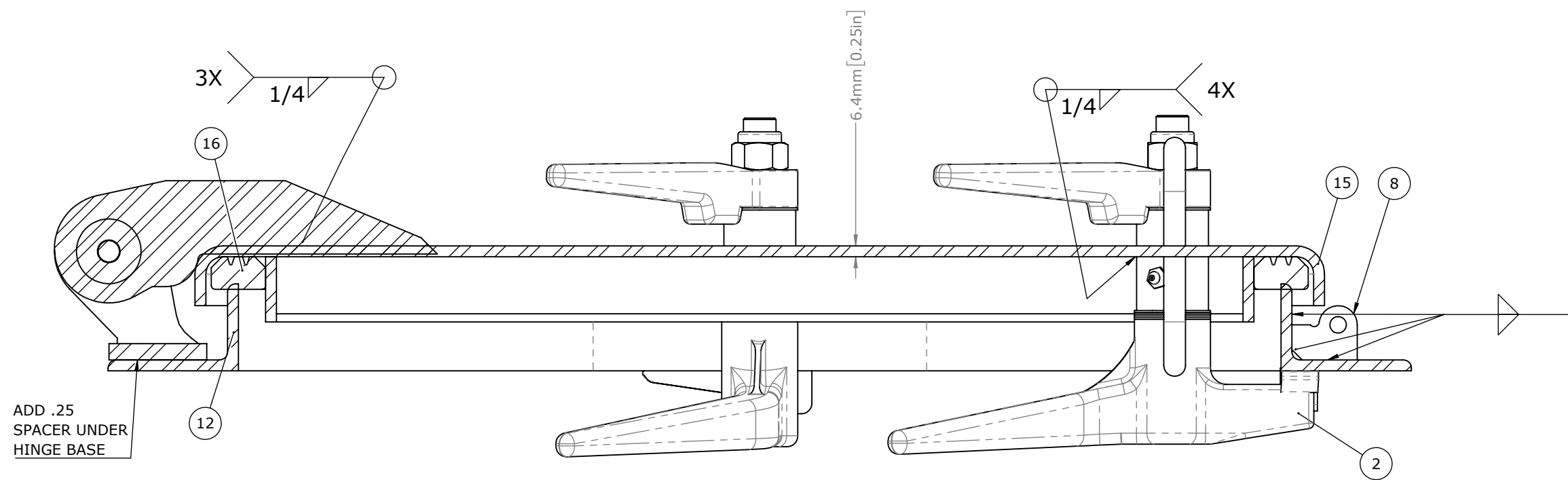

SECTION B-B
SCALE 1 : 3

REVISIONS

SEE SHEET 1

GENERAL NOTES

SEE SHEET 1

WO#

CUSTOMER APPROVAL

IMPORTANT! THIS DRAWING SUPERSEDES ALL OTHER DOCUMENTS. By signing this approval you accept and agree that the dimensions and details shown are correct and properly fit your application, regardless of any differences between this drawing and any prior contract specifications. Should you have any questions or see any errors, DO NOT SIGN THIS APPROVAL until the drawing is corrected.

SIGN _____ DATE _____

UNLESS OTHERWISE SPECIFIED, DIMENSIONS ARE IN MILLIMETERS. TOLERANCES FOR ROUGH AND CLEAR OPENINGS ARE ±3mm (.125"). ALL OTHERS ARE:

METRIC	X	.X	.XX	ANGLES
	±2.5	±.8	±.25	±2°
IMPERIAL	.X	.XX	.XXX	ANGLES
	±.1	±.03	±.010	±2°

BAR CODE _____ CAGE CODE 64747



COPYRIGHT 2014/2015 ADVANTEC GLOBAL INNOVATIONS. ALL RIGHTS RESERVED. CONFIDENTIAL PROPERTY OF ADVANTEC GLOBAL INNOVATIONS. UNAUTHORIZED USE, REPRODUCTION OR DISTRIBUTION IS STRICTLY PROHIBITED. COPIES REMAIN THE PROPERTY OF ADVANTEC GLOBAL INNOVATIONS AND MUST BE RETURNED UPON REQUEST.

CLIENT FME

PROJECT TITLE

DWG TITLE WATERTIGHT BULKHEAD DOOR QTY

SCALE 1:10 DRAWN ZJC DATE 9/21/2016 CHECKED DJM DATE 9/21/2016 SIZE B

S.O. NO DWG NO 1212-2466L SHEET 2 of 2 REV 00