

**EXTERIOR VIEW**

**SECTION A-A**

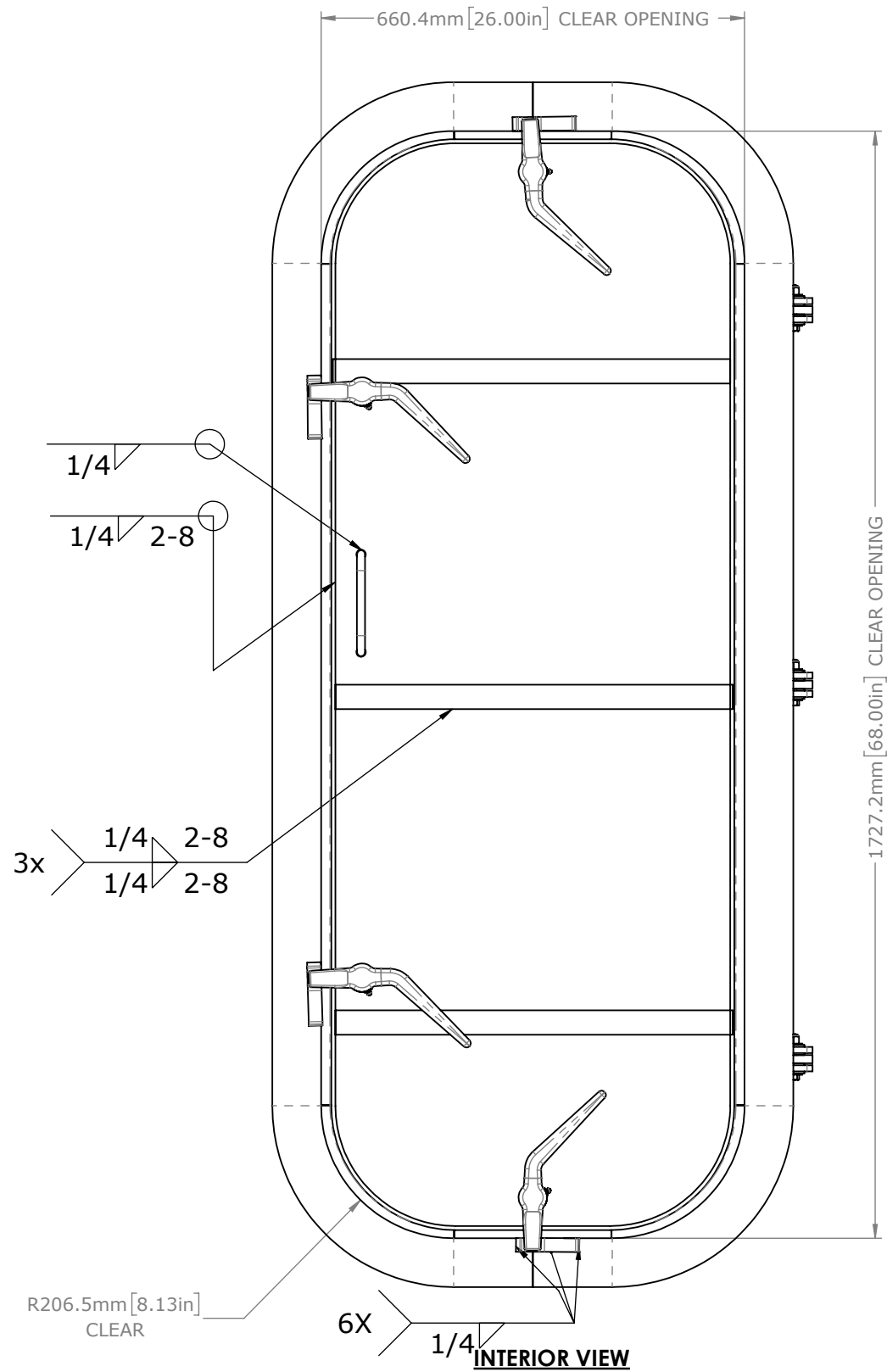

**INTERIOR VIEW**

**REVISIONS**

REV.	DESCRIPTION	BY	DATE
00	PRODUCTION RELEASE	ZJC	3/5/19

**GENERAL NOTES**

1. REMOVE ALL BURRS AND BREAK SHARP EDGES AND CORNERS 1.0mm [.04"] MAX.
2. WELD IN INSTALLATION
3. WATERTIGHT CONSTRUCTION TO MEET SEALING STD II
4. APPROX WEIGHT: 284.86kg
5. finish: B - COMMERCIAL QUALITY

WO#

**CUSTOMER APPROVAL**

IMPORTANT! THIS DRAWING SUPERSEDES ALL OTHER DOCUMENTS. By signing this approval you accept and agree that the dimensions and details shown are correct and properly fit your application, regardless of any differences between this drawing and any prior contract specifications. Should you have any questions or see any errors, DO NOT SIGN THIS APPROVAL until the drawing is corrected.

SIGN \_\_\_\_\_ DATE \_\_\_\_\_

UNLESS OTHERWISE SPECIFIED, DIMENSIONS ARE IN MILLIMETERS. TOLERANCES FOR ROUGH AND CLEAR OPENINGS ARE ±3mm (.125"). ALL OTHERS ARE:

METRIC	X	.X	.XX	ANGLES
	±2.5	±.8	±.25	±2°
IMPERIAL	.X	.XX	.XXX	ANGLES
	±.1	±.03	±.010	±2°

BAR CODE \_\_\_\_\_ CAGE CODE 64747



COPYRIGHT 20142015 ADVANTEC GLOBAL INNOVATIONS. ALL RIGHTS RESERVED. CONFIDENTIAL PROPERTY OF ADVANTEC GLOBAL INNOVATIONS. UNAUTHORIZED USE, REPRODUCTION OR DISTRIBUTION IS STRICTLY PROHIBITED. COPIES REMAIN THE PROPERTY OF ADVANTEC GLOBAL INNOVATIONS AND MUST BE RETURNED UPON REQUEST.

CLIENT FME

PROJECT TITLE

DWG TITLE					QTY
WATERTIGHT BULKHEAD DOOR					
SCALE	DRAWN	DATE	CHECKED	DATE	SIZE
1:10	ZC	3/5/2019	RW	3/5/2019	B
S.O. NO	DWG NO	SHEET		REV	
	1212-2668L	1 of 2		00	

ITEM	QTY	PART No.	DESCRIPTION	MATERIAL
1	1	0223-1002	DOG ASSY, INDIVIDUAL, RH	REF S.A. BOM
2	3	0223-1003	DOG ASSY, INDIVIDUAL,STEEL, LH	REF S.A. BOM
3	2	0243-2031	PULL HANDLE	BAR, STL A36 .5IN DIA ROUND (0615-9600)
4	3	0411-2027	NUT .50IN-13 SS 316 NYLOCK	SS 316/316L
5	3	0411-2029	SCREW, HH .5-13X2.5IN	SS 316/316L
6	6	0411-2693	WASHER, FLAT	SS 316/316L
7	4	0411-3084	WASHER, FLAT 3/4 SAE, S/S	SS 316/316L
8	12	0413-2114	WASHER, .521 X 1.49 X .125 NYLON	Nylon 6/10
9	1	0422-2800	PADLOCK HASP	PLATE, STL .188IN A36 (0715-2033)
10	1	0422-2800	PADLOCK HASP	PLATE, STL .188IN A36 (0715-2033)
11	3	0462-2579	BASE, HINGE	PLATE, STL .375IN A36 GRY (0715-2026)
12	3	0462-2591	HINGE,PANEL SIDE,BULKHEAD DOOR,FIXED	A36
13	4	0616-2078	STOP, DOG A36 .5 DIA ROUND X 1.375	A36 STEEL
14	3	0616-2079	STIFFENER ANGLE .25X1.5X1.5X24.44	ANGLE, STL A36 HR 1.5X1.5X.25IN (0615-9503)
15	2	0616-2103	COAMING	ANGLE, STL A36 HR 3X2X.25IN (0615-9587)
16	2	0616-2105	GASKET RETAINER/STIFFENER	BAR, STL A36 HR .25X1.5IN (0615-9598)
17	1	0716-2072	SKIN, EXT STL A36 .25 THICK LH 2668 CO	PLATE, STL .25IN ABS A36 (0715-2020)
18	1	1212-2668L-203	GASKET	25 DURO NEOPRENE (0631-9854)

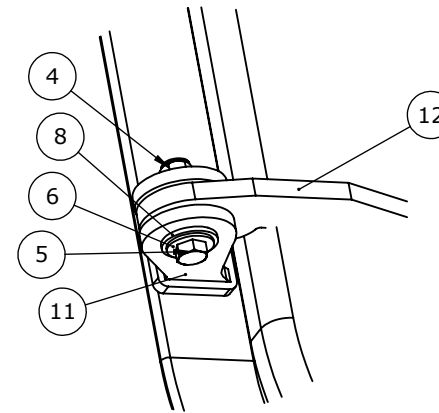

DETAIL K  
SCALE 1 : 5

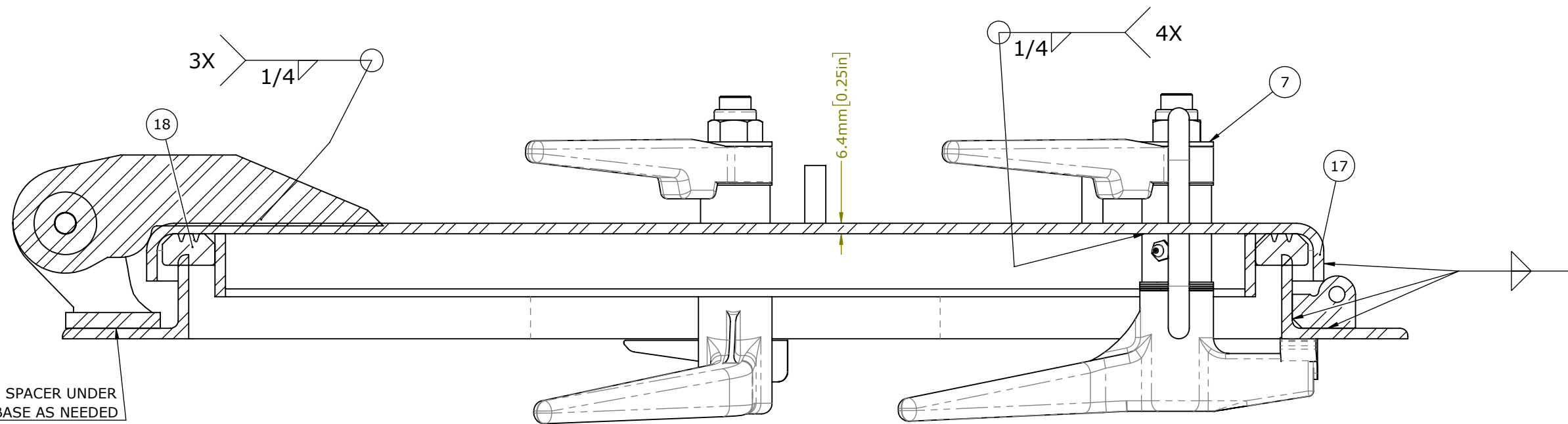

SECTION B-B  
SCALE 1 : 3

**REVISIONS**

SEE SHEET 1

**GENERAL NOTES**

SEE SHEET 1

WO#

**CUSTOMER APPROVAL**

IMPORTANT! THIS DRAWING SUPERSEDES ALL OTHER DOCUMENTS. By signing this approval you accept and agree that the dimensions and details shown are correct and properly fit your application, regardless of any differences between this drawing and any prior contract specifications. Should you have any questions or see any errors, DO NOT SIGN THIS APPROVAL until the drawing is corrected.

SIGN \_\_\_\_\_ DATE \_\_\_\_\_

UNLESS OTHERWISE SPECIFIED, DIMENSIONS ARE IN MILLIMETERS. TOLERANCES FOR ROUGH AND CLEAR OPENINGS ARE ±3mm (.125"). ALL OTHERS ARE:

METRIC	X	.X	.XX	ANGLES
	±2.5	±.8	±.25	±2°
IMPERIAL	.X	.XX	.XXX	ANGLES
	±.1	±.03	±.010	±2°

BAR CODE	CAGE CODE
	64747



COPYRIGHT 2014/2015 ADVANTEC GLOBAL INNOVATIONS. ALL RIGHTS RESERVED. CONFIDENTIAL PROPERTY OF ADVANTEC GLOBAL INNOVATIONS. UNAUTHORIZED USE, REPRODUCTION OR DISTRIBUTION IS STRICTLY PROHIBITED. COPIES REMAIN THE PROPERTY OF ADVANTEC GLOBAL INNOVATIONS AND MUST BE RETURNED UPON REQUEST.

CLIENT FME

PROJECT TITLE

DWG TITLE WATERTIGHT BULKHEAD DOOR QTY

SCALE	DRAWN	DATE	CHECKED	DATE	SIZE
1:10	ZC	3/5/2019	RW	3/5/2019	B

S.O. NO	DWG NO	SHEET	REV
	1212-2668L	2 of 2	00