

EXTERIOR VIEW

SECTION A-A

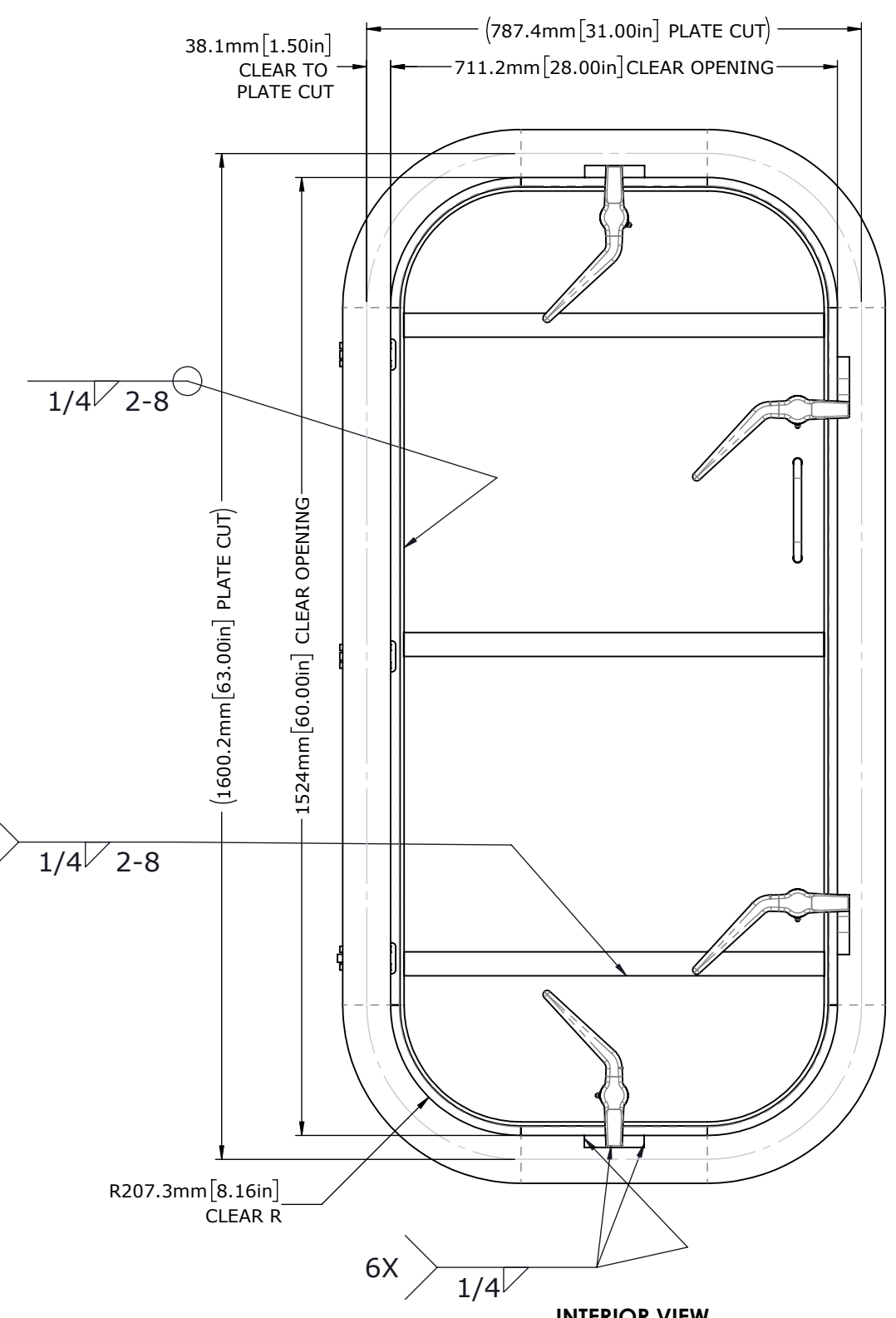

INTERIOR VIEW

REVISIONS

REV.	DESCRIPTION	BY	DATE
A	PRODUCTION RELEASE	ZJC	22SEP16

GENERAL NOTES

1. REMOVE ALL BURRS AND BREAK SHARP EDGES AND CORNERS 1.0mm [.04"] MAX.
2. WELD IN INSTALLATION
3. WATERTIGHT CONSTRUCTION TO MEET SEALING STD II
4. APPROX WEIGHT: 270.62kg
5. finish: B - COMMERCIAL QUALITY

WO#

CUSTOMER APPROVAL

IMPORTANT! THIS DRAWING SUPERSEDES ALL OTHER DOCUMENTS. By signing this approval you accept and agree that the dimensions and details shown are correct and properly fit your application, regardless of any differences between this drawing and any prior contract specifications. Should you have any questions or see any errors, DO NOT SIGN THIS APPROVAL until the drawing is corrected.

SIGN _____ DATE _____

UNLESS OTHERWISE SPECIFIED, DIMENSIONS ARE IN MILLIMETERS. TOLERANCES FOR ROUGH AND CLEAR OPENINGS ARE ±3mm (.125"). ALL OTHERS ARE:

METRIC	X	.X	.XX	ANGLES
	±2.5	±.8	±.25	±2°
IMPERIAL	.X	.XX	.XXX	ANGLES
	±.1	±.03	±.010	±2°

BAR CODE _____ CAGE CODE 64747



COPYRIGHT 20142015 ADVANTEC GLOBAL INNOVATIONS. ALL RIGHTS RESERVED. CONFIDENTIAL PROPERTY OF ADVANTEC GLOBAL INNOVATIONS. UNAUTHORIZED USE, REPRODUCTION OR DISTRIBUTION IS STRICTLY PROHIBITED. COPIES REMAIN THE PROPERTY OF ADVANTEC GLOBAL INNOVATIONS AND MUST BE RETURNED UPON REQUEST.

CLIENT **FME**

PROJECT TITLE _____

DWG TITLE **WATERTIGHT BULKHEAD DOOR** QTY _____

SCALE	DRAWN	DATE	CHECKED	DATE	SIZE
1:10	ZJC	22-Sep-16	DJM	22-Sep-16	B

S.O. NO	DWG NO	SHEET	REV
	1212-2860R	1 of 3	A

ITEM	QTY	PART No.	DESCRIPTION	MATERIAL
1	3	0223-1002	DOG ASSY, INDIVIDUAL, CENTEX, STEEL, RH	STEEL
2	1	0223-1003	DOG ASSY, INDIVIDUAL, CENTEX, STEEL, LH	STEEL
3	3	0411-2029	SCREW, HH .5-13X2.5IN	STAINLESS STEEL, 316
4	6	0411-2693	WASHER, FLAT	316/316L STAINLESS STEEL
5	12	0413-2111	WASHER	Nylon 6/10
6	3	0462-2637	HINGE BASE	STAINLESS STEEL
7	3	0462-2574	BLADE, HINGE	PLATE, STL .50IN A36 (0715-2028)
8	3	0411-2027	NUT .50IN-13 SS 316 NYLOCK	SS 316/316L
9	1	1212-2860R-101	MAIN FRAME	ANGLE, STL A36 HR 3X2X.313IN (0615-9534)
10	1	P0004801-001-102	PADLOCK HASP	PLATE, STL .188IN A36 (0715-2033)
11	4	1212-2860R-103	QUICK ACTING DOG WEDGE	BAR, STL A36 HR .375X1IN (0615-9581)
12	1	1212-2860R-201	SKIN, EXTERIOR	.25IN THK A36 GRY STL (0715-2027)
13	1	1212-2860R-202	GASKET RETAINER/STIFFENER	.25X1.5IN., A36 (0615-9598)
14	1	1212-2860R-203	GASKET	25 DURO NEOPRENE (0631-9854)
15	1	1212-2860R-207	PADLOCK HASP	PLATE, STL .188IN A36 (0715-2033)
16	3	1212-2860R-208	STIFFENER	.25X1.0IN., A36 (0715-9598)
17	2	1212-2860R-204	PULL HANDLE	BAR, STL A36 .5IN DIA ROUND (0615-9600)

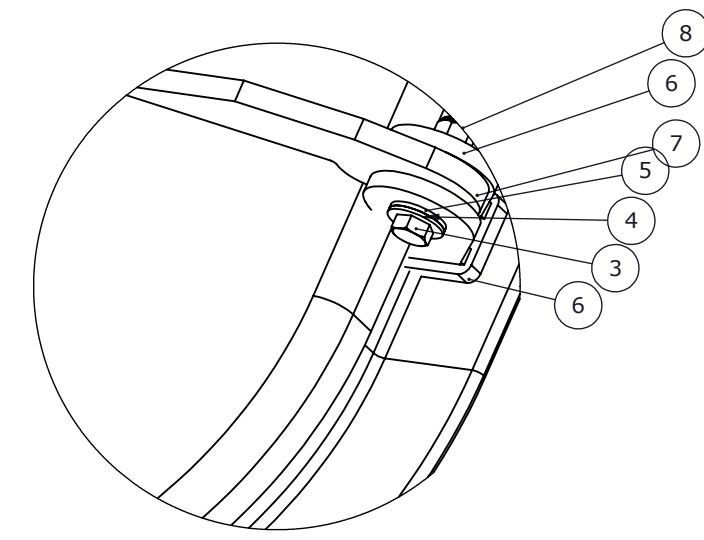

DETAIL F
SCALE 1 : 4

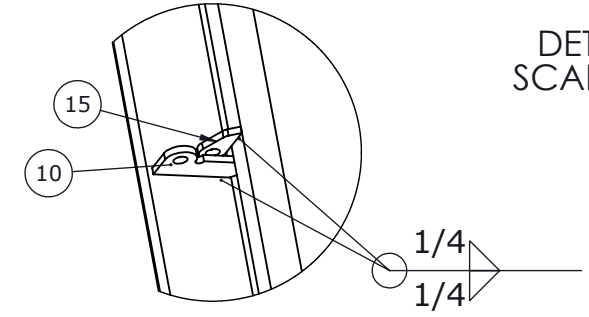

DETAIL G
SCALE 1 : 5

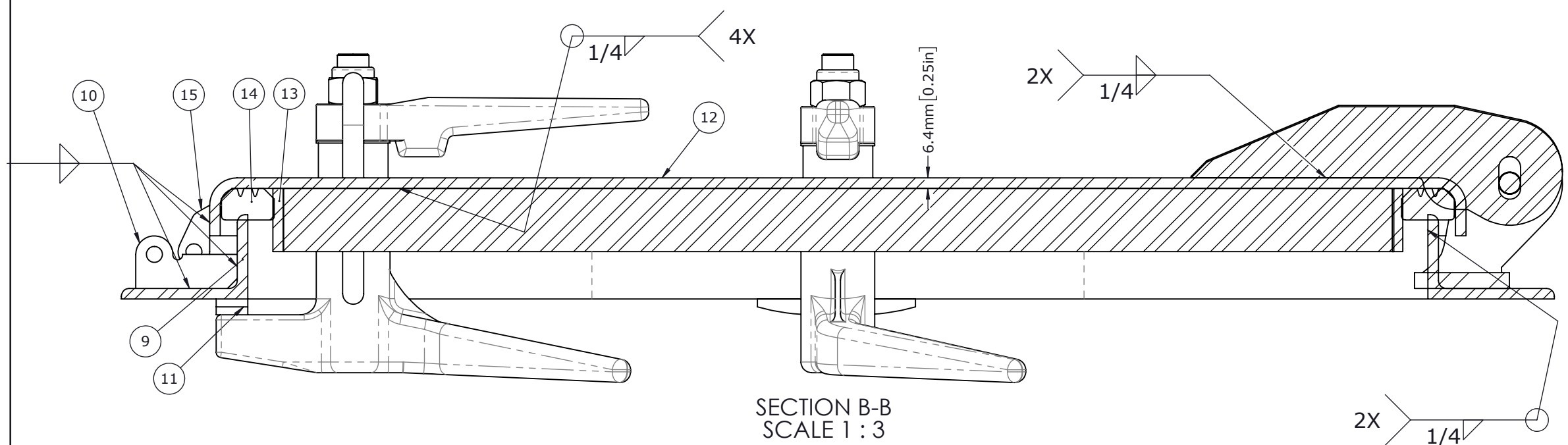

SECTION B-B
SCALE 1 : 3

REVISIONS

SEE SHEET 1

GENERAL NOTES

SEE SHEET 1

WO#

CUSTOMER APPROVAL

IMPORTANT! THIS DRAWING SUPERSEDES ALL OTHER DOCUMENTS. By signing this approval you accept and agree that the dimensions and details shown are correct and properly fit your application, regardless of any differences between this drawing and any prior contract specifications. Should you have any questions or see any errors, DO NOT SIGN THIS APPROVAL until the drawing is corrected.

SIGN _____ DATE _____

UNLESS OTHERWISE SPECIFIED, DIMENSIONS ARE IN MILLIMETERS. TOLERANCES FOR ROUGH AND CLEAR OPENINGS ARE ±3mm (.125"). ALL OTHERS ARE:

	X	.X	.XX	ANGLES
METRIC	±2.5	±.8	±.25	±2°
IMPERIAL	.X	.XX	.XXX	ANGLES
	±.1	±.03	±.010	±2°

BAR CODE _____ CAGE CODE 64747



COPYRIGHT 2014/2015 ADVANTEC GLOBAL INNOVATIONS. ALL RIGHTS RESERVED. CONFIDENTIAL PROPERTY OF ADVANTEC GLOBAL INNOVATIONS. UNAUTHORIZED USE, REPRODUCTION OR DISTRIBUTION IS STRICTLY PROHIBITED. COPIES REMAIN THE PROPERTY OF ADVANTEC GLOBAL INNOVATIONS AND MUST BE RETURNED UPON REQUEST.

CLIENT FME

PROJECT TITLE _____

DWG TITLE WATERTIGHT BULKHEAD DOOR QTY _____

SCALE	DRAWN	DATE	CHECKED	DATE	SIZE
1:10	ZJC	22-Sep-16	DJM	22-Sep-16	B

S.O. NO. _____ DWG NO. 1212-2860R SHEET 2 of 3 REV A

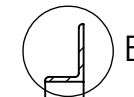
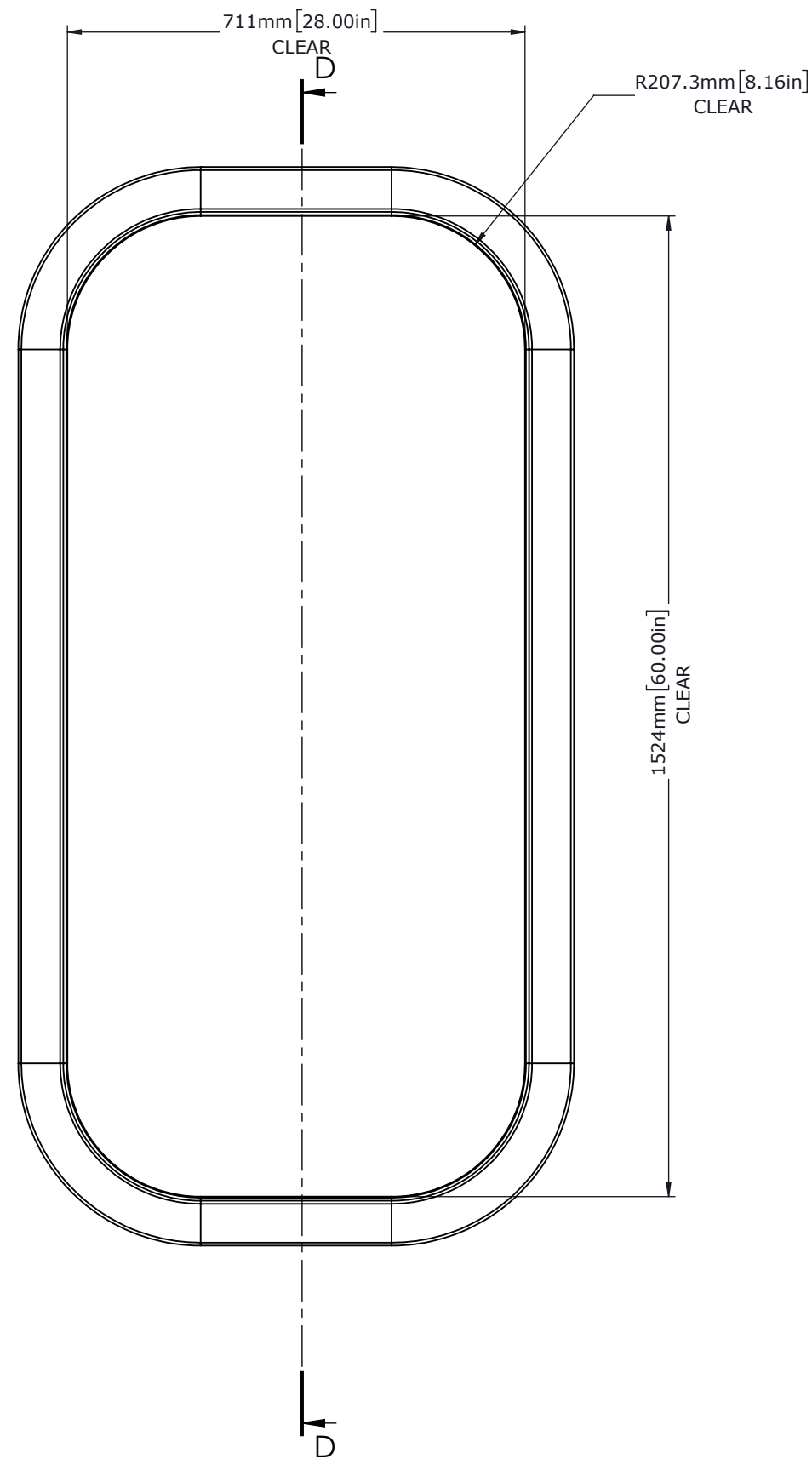

SECTION D-D

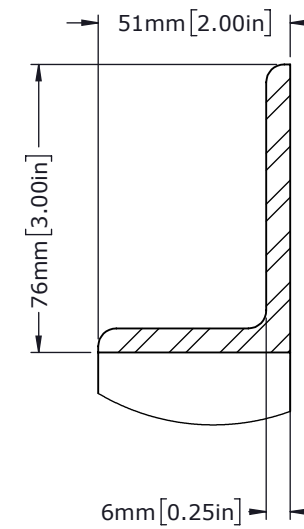

DETAIL E
SCALE 1 : 2

REVISIONS

GENERAL NOTES

1. REMOVE ALL BURRS AND BREAK SHARP EDGES AND CORNERS 1.0mm [.04"] MAX.
2. finish: B - COMMERCIAL QUALITY
3. MATERIAL: 2X3X.312 A36 MS

WO#

CUSTOMER APPROVAL

IMPORTANT! THIS DRAWING SUPERSEDES ALL OTHER DOCUMENTS. By signing this approval you accept and agree that the dimensions and details shown are correct and properly fit your application, regardless of any differences between this drawing and any prior contract specifications. Should you have any questions or see any errors, DO NOT SIGN THIS APPROVAL until the drawing is corrected.

SIGN

DATE

UNLESS OTHERWISE SPECIFIED, DIMENSIONS ARE IN MILLIMETERS. TOLERANCES FOR ROUGH AND CLEAR OPENINGS ARE $\pm 3\text{mm}$ (.125"). ALL OTHERS ARE:

METRIC	X ± 2.5	.X $\pm .8$.XX $\pm .25$	ANGLES $\pm 2^\circ$
IMPERIAL	.X $\pm .1$.XX $\pm .03$.XXX $\pm .010$	ANGLES $\pm 2^\circ$

BAR CODE

CAGE CODE

64747



COPYRIGHT 2014/2015 ADVANTEC GLOBAL INNOVATIONS. ALL RIGHTS RESERVED. CONFIDENTIAL PROPERTY OF ADVANTEC GLOBAL INNOVATIONS. UNAUTHORIZED USE, REPRODUCTION OR DISTRIBUTION IS STRICTLY PROHIBITED. COPIES REMAIN THE PROPERTY OF ADVANTEC GLOBAL INNOVATIONS AND MUST BE RETURNED UPON REQUEST.

CLIENT

FME

PROJECT TITLE

DWG TITLE

MAIN FRAME

QTY

SCALE	DRAWN	DATE	CHECKED	DATE	SIZE
1:10	ZJC	22-Sep-16	DJM	22-Sep-16	B

S.O. NO	DWG NO	SHEET	REV
	1212-2860R-101	3 of 3	A