

EXTERIOR VIEW

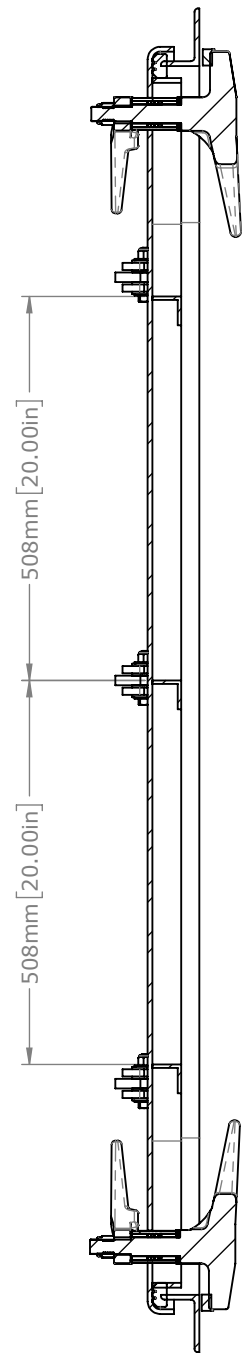

SECTION A-A

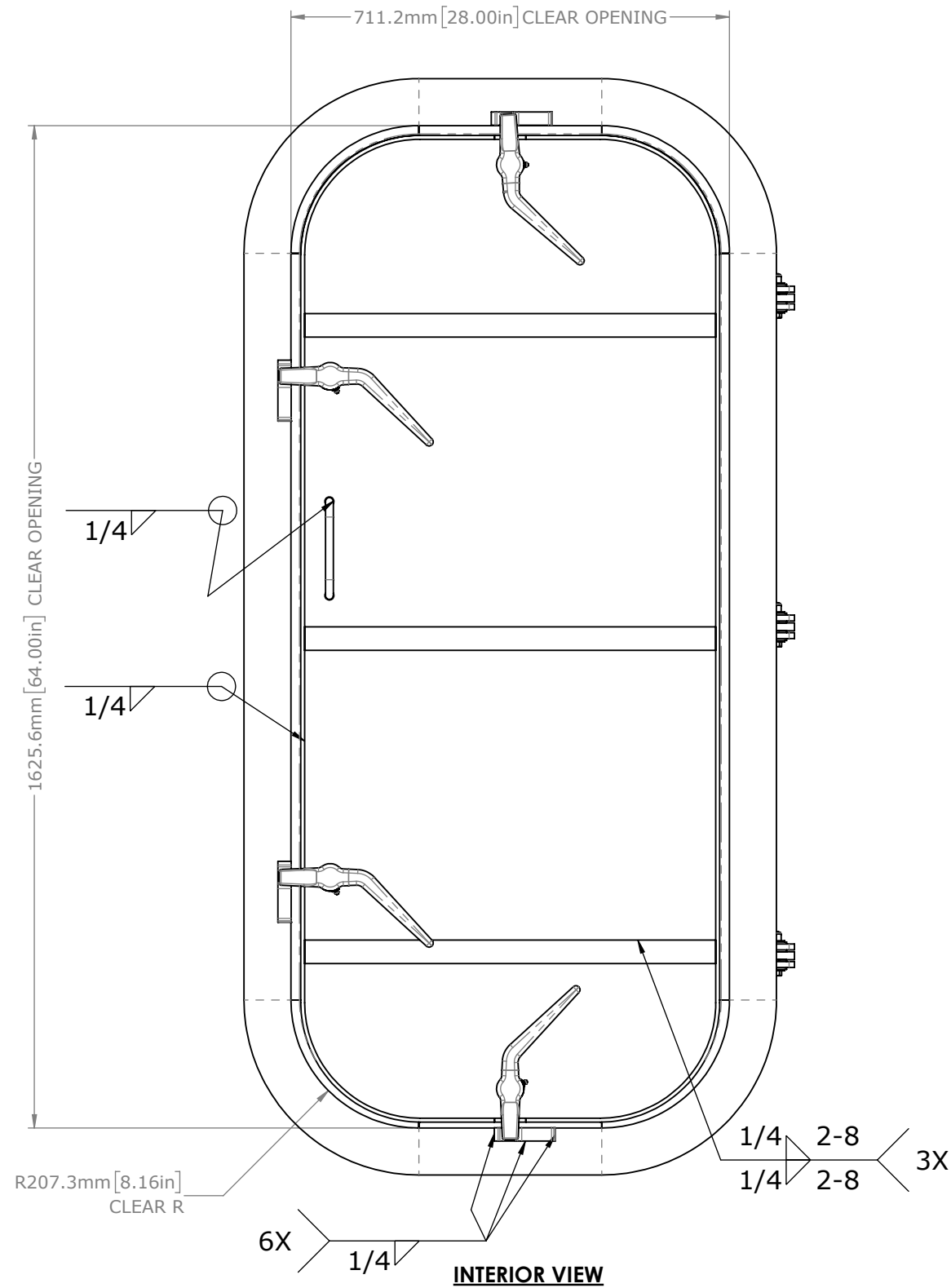

INTERIOR VIEW

REVISIONS

REV.	DESCRIPTION	BY	DATE
00	PRODUCTION RELEASE	ZJC	2/25/19

GENERAL NOTES

1. REMOVE ALL BURRS AND BREAK SHARP EDGES AND CORNERS 1.0mm [.04"] MAX.
2. WELD IN INSTALLATION
3. WATERTIGHT CONSTRUCTION TO MEET SEALING STD II
4. APPROX WEIGHT: 284.63kg
5. finish: B - COMMERCIAL QUALITY

WO#

CUSTOMER APPROVAL

IMPORTANT! THIS DRAWING SUPERSEDES ALL OTHER DOCUMENTS. By signing this approval you accept and agree that the dimensions and details shown are correct and properly fit your application, regardless of any differences between this drawing and any prior contract specifications. Should you have any questions or see any errors, DO NOT SIGN THIS APPROVAL until the drawing is corrected.

SIGN _____ DATE _____

UNLESS OTHERWISE SPECIFIED, DIMENSIONS ARE IN MILLIMETERS. TOLERANCES FOR ROUGH AND CLEAR OPENINGS ARE ±3mm (.125"). ALL OTHERS ARE:

METRIC	X	.X	.XX	ANGLES
	±2.5	±.8	±.25	±2°
IMPERIAL	.X	.XX	.XXX	ANGLES
	±.1	±.03	±.010	±2°

BAR CODE _____ CAGE CODE 64747



COPYRIGHT 20142015 ADVANTEC GLOBAL INNOVATIONS. ALL RIGHTS RESERVED. CONFIDENTIAL PROPERTY OF ADVANTEC GLOBAL INNOVATIONS. UNAUTHORIZED USE, REPRODUCTION OR DISTRIBUTION IS STRICTLY PROHIBITED. COPIES REMAIN THE PROPERTY OF ADVANTEC GLOBAL INNOVATIONS AND MUST BE RETURNED UPON REQUEST.

CLIENT **FME**

PROJECT TITLE

DWG TITLE **WATERTIGHT BULKHEAD DOOR** QTY

SCALE 1:10 DRAWN ZJC DATE 2/25/2019 CHECKED RW DATE 2/25/2019 SIZE B

S.O. NO DWG NO 1212-2864L SHEET 1 of 2 REV 00

ITEM	QTY	PART No.	DESCRIPTION	MATERIAL
1	1	0223-1002	DOG ASSY, INDIVIDUAL, RH	REF S.A. BOM
2	3	0223-1003	DOG ASSY, INDIVIDUAL,STEEL, LH	REF S.A. BOM
3	2	0243-2031	PULL HANDLE	BAR, STL A36 .5IN DIA ROUND (0615-9600)
4	3	0411-2027	NUT .50IN-13 SS 316 NYLOCK	SS 316/316L
5	3	0411-2029	SCREW, HH .5-13X2.5IN	SS 316/316L
6	6	0411-2693	WASHER, FLAT	SS 316/316L
7	12	0413-2114	WASHER, .521 X 1.49 X .125 NYLON	Nylon 6/10
8	1	0422-2800	PADLOCK HASP	PLATE, STL .188IN A36 (0715-2033)
9	1	0422-2801	PADLOCK HASP	PLATE, STL .188IN A36 (0715-2033)
10	3	0462-2579	BASE, HINGE	PLATE, STL .375IN A36 GRY (0715-2026)
11	3	0462-2591	HINGE,PANEL SIDE,BULKHEAD DOOR,FIXED	A36
12	2	0616-2102	BEND, HALF CMG ANGLE STL 3X2X.25 64 CO	ANGLE, STL A36 HR 3X2X.313IN (0615-9534)
13	4	0616-2078	STOP, DOG STEEL .5 DIA ROUND X 1.375	STEEL
14	3	0616-2080	STIFFNER, ANGLE .25X1.5X1.5X26.44 A36	ANGLE, STL A36 HR 1.5X1.5X.25IN (0615-9503)
15	2	0616-2104	GASKET RETAINER/STIFFENER	A36
16	1	0716-2074	SKIN, EXT STL A36 .25 THICK LH 2864 CO	PLATE, STL .25IN ABS A36 (0715-2020)
17	1	1212-2864L-203	GASKET	25 DURO NEOPRENE (0631-9854)

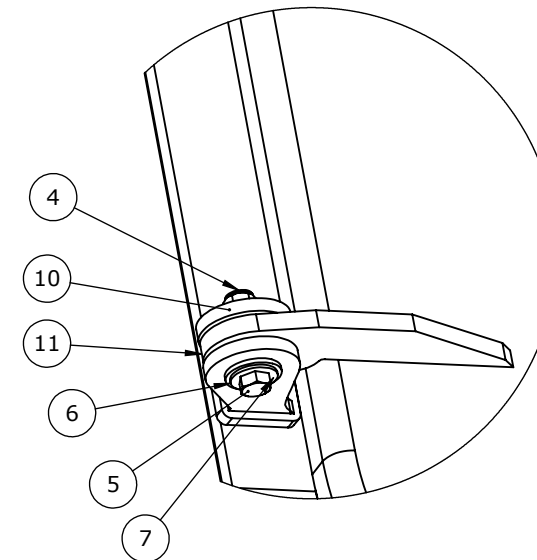

DETAIL J
SCALE 1 : 5

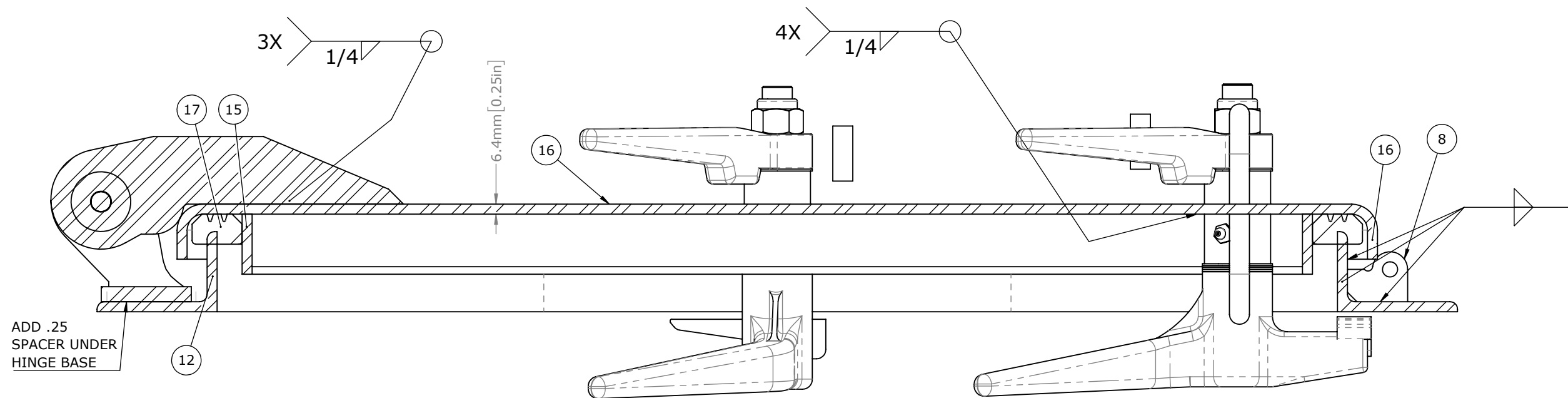

SECTION B-B
SCALE 1 : 3

REVISIONS

SEE SHEET 1

GENERAL NOTES

SEE SHEET 1

WO#

CUSTOMER APPROVAL

IMPORTANT! THIS DRAWING SUPERSEDES ALL OTHER DOCUMENTS. By signing this approval you accept and agree that the dimensions and details shown are correct and properly fit your application, regardless of any differences between this drawing and any prior contract specifications. Should you have any questions or see any errors, DO NOT SIGN THIS APPROVAL until the drawing is corrected.

SIGN _____ DATE _____

UNLESS OTHERWISE SPECIFIED, DIMENSIONS ARE IN MILLIMETERS. TOLERANCES FOR ROUGH AND CLEAR OPENINGS ARE ±3mm (.125"). ALL OTHERS ARE:

	X	.X	.XX	ANGLES
METRIC	±2.5	±.8	±.25	±2°
IMPERIAL	.X	.XX	.XXX	ANGLES
	±.1	±.03	±.010	±2°

BAR CODE _____ CAGE CODE
64747



COPYRIGHT 20142015 ADVANTEC GLOBAL INNOVATIONS. ALL RIGHTS RESERVED. CONFIDENTIAL PROPERTY OF ADVANTEC GLOBAL INNOVATIONS. UNAUTHORIZED USE, REPRODUCTION OR DISTRIBUTION IS STRICTLY PROHIBITED. COPIES REMAIN THE PROPERTY OF ADVANTEC GLOBAL INNOVATIONS AND MUST BE RETURNED UPON REQUEST.

CLIENT
FME

PROJECT TITLE

DWG TITLE
WATERTIGHT BULKHEAD DOOR

SCALE 1:10 DRAWN ZJC DATE 2/25/2019 CHECKED RW DATE 2/25/2019 SIZE B

S.O. NO _____ DWG NO 1212-2864L SHEET 2 of 2 REV 00