

EXTERIOR VIEW

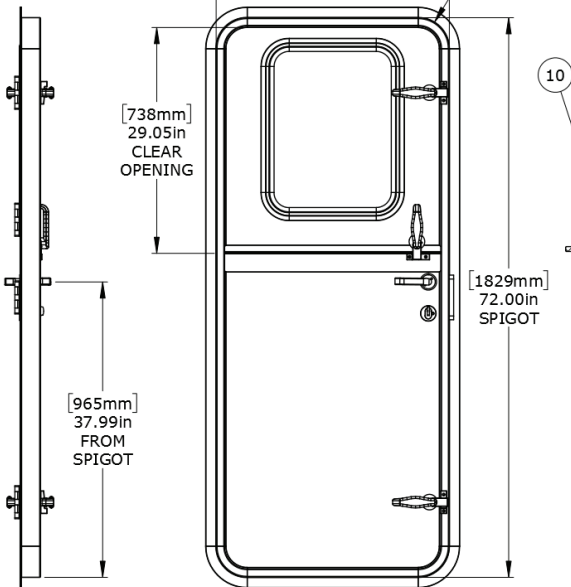

INTERIOR VIEW

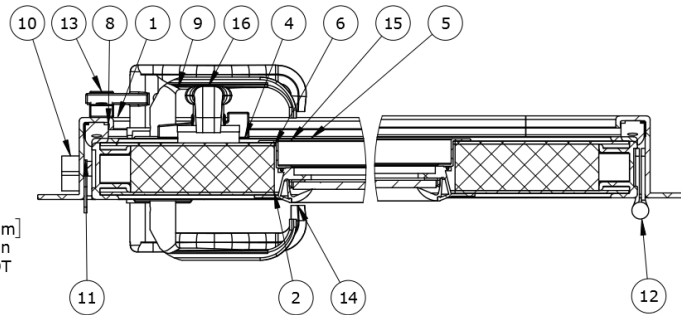

DETAIL B
SCALE 1 : 4

DETAIL C
SCALE 1 : 4

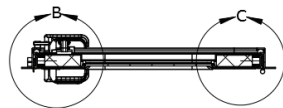

SECTION A-A
SCALE 1 : 16

REVISIONS

REV #	DESCRIPTION	DATE

GENERAL NOTES

1. INSTALLATION: BOLT OR WELD-IN.
2. BUILD TO SPIGOT.
3. WEATHER TIGHT CONSTRUCTION.
4. GLASS SHALL BE 1/4" CLEAR TEMPERED.
5. APPROXIMATE WEIGHT: 76.6KG (169LBS.)
6. FINISH: BARE METAL.
7. FOR ADDITIONAL INFORMATION CONTACT YOUR SALES REPRESENTATIVE OR PROJECT MANAGER.

CUSTOMER APPROVAL

IMPORTANT! THIS DRAWING SUPERSEDES ALL OTHER DOCUMENTS. BY SIGNING THIS APPROVAL, YOU ACCEPT AND AGREE THAT THE DIMENSIONS AND DETAILS SHOWN ARE CORRECT AND PROPERLY FIT YOUR APPLICATION. RESOLUTION OF ANY DISCREPANCIES BETWEEN THIS DRAWING AND ANY PRIOR CONTRACT SPECIFICATIONS, SHOULD YOU HAVE ANY QUESTIONS OR SEE ANY ERRORS, DO NOT SIGN THIS APPROVAL UNTIL THE DRAWING IS CORRECTED.

SIGN _____ DATE _____

UNLESS OTHERWISE SPECIFIED, DIMENSIONS ARE IN MILLIMETERS. TOLERANCES FOR ROUGH AND CLEAR OPENINGS ARE ±3mm (.125"). ALL OTHERS ARE:

METRIC	X	.X	.XX	ANGLES
	±2.5	±.8	±.25	±2°
IMPERIAL	.X	.XX	.XXX	ANGLES
	±.1	±.03	±.010	±2°

BAR CODE _____ CAGE CODE _____

ITEM NO.	PART NUMBER	DESCRIPTION	QTY.
1	D11436	MAIN FRAME	1
2	D11354	TOP SKIN	2
3	D11354	BOTTOM SKIN	2
4	D11435	UPPER PANEL EDGE	1
5	D11435	LOWER PANEL EDGE	1
6	D11481	1-1/2" POLYSTYRENE	1
7	D11481	1-1/2" POLYSTYRENE	1
8	D10847	GASKET	1
9	D11237	TRIOVING 5312	1
10	D12015	DEADBOLT RECESS	1
11	D10293	500 STRIKER PLATE	1
12	D10480	4 X 4 SLOTTED HINGE	4
13	D11129	DOG WEDGE	3
14	D11252	DOG, HANDLE, NYLON, SET, 250	2
15	D5 Window	WINDOW	1
16	D12836	Nylon 250 Dutch Blind Dog Set - RH	1



COPYRIGHT 2015 ADVANTEC GLOBAL INNOVATIONS. ALL RIGHTS RESERVED. CONFIDENTIAL PROPERTY OF ADVANTEC GLOBAL INNOVATIONS. UNAUTHORIZED USE, REPRODUCTION OR DISTRIBUTION IS STRICTLY PROHIBITED. COPIES REMAIN THE PROPERTY OF ADVANTEC GLOBAL INNOVATIONS AND MUST BE RETURNED UPON REQUEST.

CLIENT _____

PROJECT TITLE
WEATHERTIGHT DUTCH DOOR

DWG TITLE
MODEL 30" X 72" RH

SCALE DRAWN DATE CHECKED DATE SIZE B

S.O. NO. DWG NO. SHEET 23 OF 27 REV

250-DUTCH DOOR