

EXTERIOR VIEW

INTERIOR VIEW

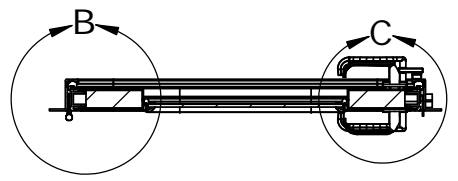

SECTION A-A  
SCALE 1 : 16

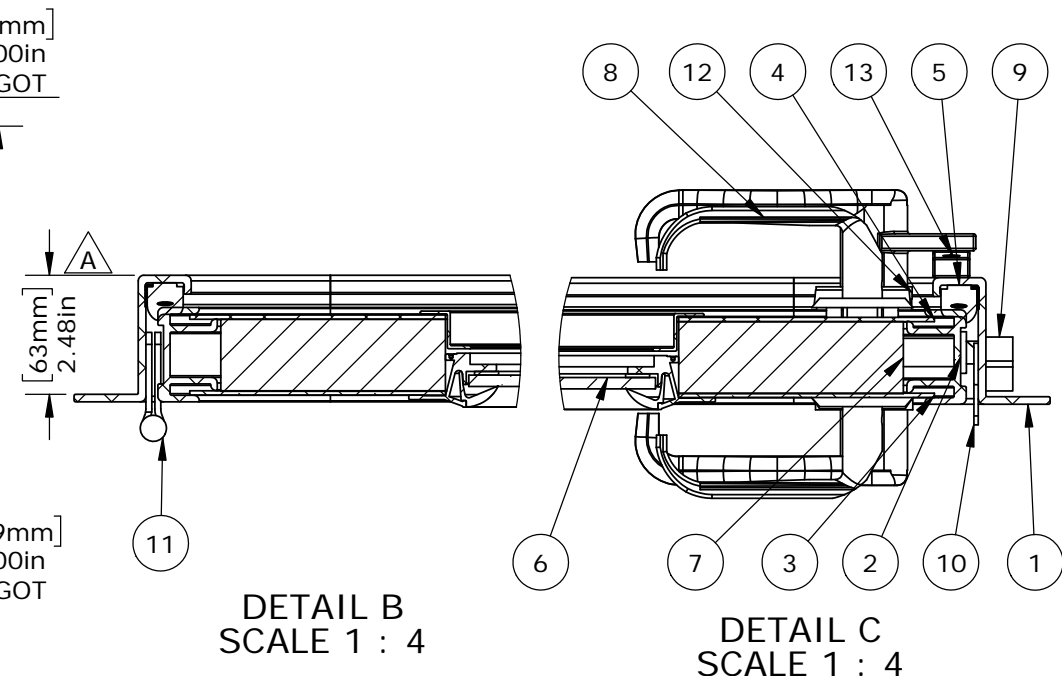

DETAIL B  
SCALE 1 : 4

DETAIL C  
SCALE 1 : 4

REVISIONS			
REV.	DESCRIPTION	BY	DATE
A	ADDED DIMENSION	WDR	4/3/2017

- GENERAL NOTES**
1. INSTALLATION: BOLT OR WELD-IN
  2. BUILD TO SPIGOT.
  3. GLASS SHALL BE 1/4" CLEAR TEMPERED.
  4. WEATHERTIGHT DOOR CONSTRUCTION.
  5. APPROX WEIGHT: 42.547kg (93.8 LBS.)
  6. FINISH: BARE METAL
  7. FOR ADDITIONAL INFORMATION CONTACT YOUR SALES REPRESENTATIVE OR PROJECT MANAGER.

**CUSTOMER APPROVAL**  
 IMPORTANT! THIS DRAWING SUPERSEDES ALL OTHER DOCUMENTS. BY SIGNING THIS APPROVAL YOU ACCEPT AND AGREE THAT THE DIMENSIONS AND DETAILS SHOWN ARE CORRECT AND PROPERLY FIT YOUR APPLICATION, REGARDLESS OF ANY DIFFERENCES BETWEEN THIS DRAWING AND ANY PRIOR CONTRACT SPECIFICATIONS. SHOULD YOU HAVE ANY QUESTIONS OR SEE ANY ERRORS, DO NOT SIGN THIS APPROVAL UNTIL THE DRAWING IS CORRECTED.

SIGN \_\_\_\_\_ DATE \_\_\_\_\_

UNLESS OTHERWISE SPECIFIED, DIMENSIONS ARE IN MILLIMETERS. TOLERANCES FOR ROUGH AND CLEAR OPENINGS ARE ±3mm (.125"). ALL OTHERS ARE:

METRIC	X	.X	.XX	ANGLES
	±2.5	±.8	±.25	±2°
IMPERIAL	.X	.XX	.XXX	ANGLES
	±.1	±.03	±.010	±2°

BAR CODE \_\_\_\_\_ CAGE CODE \_\_\_\_\_

ITEM NO.	PART NUMBER	DESCRIPTION	QTY.
1	D11436	MAIN FRAME	1
2	D11435	PANEL EDGE	1
3	D11354	EXTERIOR SKIN	1
4	D11354	INTERIOR SKIN	1
5	D10847	GASKET	1
6	D5 WINDOW	WINDOW	1
7	D11481	1-1/2" POLYSTYRENE	1
8	D11234	TRIOVING 5312	1
9	D12015	DEADBOLT RECESS	1
10	D10293	500 STRIKER PLATE	1
11	D10480	4 X 4 SLOTTED HINGE	3
12	D11252	DOG, HANDLE, NYLON, SET, 250	2
13	D11129	DOG WEDGE	2

**Diamond Sea Glaze**  
An AdvanTec Company

COPYRIGHT 2015 ADVANTEC GLOBAL INNOVATIONS. ALL RIGHTS RESERVED. CONFIDENTIAL PROPERTY OF ADVANTEC GLOBAL INNOVATIONS. UNAUTHORIZED USE, REPRODUCTION OR DISTRIBUTION IS STRICTLY PROHIBITED. COPIES REMAIN THE PROPERTY OF ADVANTEC GLOBAL INNOVATIONS AND MUST BE RETURNED UPON REQUEST.

CLIENT _____			
PROJECT TITLE <b>WEATHERTIGHT HINGED DOOR</b>			
DWG TITLE <b>MODEL 30" X 72" LH</b>			QTY <b>1</b>
SCALE 1:24	DRAWN WDR	DATE 12/19/16	CHECKED DATE
S.O. NO.		DWG NO. <b>250-STOCK DOOR</b>	SHEET 9 of 27
			REV <b>A</b>