

SECTION B-B

ITEMS			
ID	DESCRIPTION	MATERIAL	PART NUMBER
1	MOUNTING FRAME	6063 ALUMINUM	MT - EX53887
2	FRAME INTERLOCK	6063 ALUMINUM	MT - EX53888
3	INSERT INTERLOCK	6063 ALUMINUM	MT - EX780877
4	INSERT	6063 ALUMINUM	MT - EX781120
5	STOP	6063 ALUMINUM	MT - EX627079
6	SKIN	6063 ALUMINUM	MT - SH5X12.091
7	INSULATION	KOROLITE 1"	MT - MI4140
8	BOTTOM SLIDE BLOCK	BLACK PVC	HW - CUDIA018
9	TOP SLIDE BLOCK	BLACK PVC	HW - CUDIA017
10	GLIDER BLOCK SCREW	S.S.	FA-FH/S3013
11	STOP SCREW COVER	BLACK PVC	AD - VY1177G
12	STOP SCREW	SS	FA-PH/S3131
13	DOOR WINDOW		AD - WS270_7532
14	300 TRACK	BLACK PVC	AD-VY1723
15	WEATHER STRIPPING	HAIR	AD - WS270_7532
16	BEDDING COMPOUND	CUSTOMER SUPPLY	
17	STOP BLOCK	BLACK PVC	HD-D10307
18	TRIOVING LOCKSET		HW-LS5382/8
19	INSERT INTERLOCK SCREW	SS	FA-FH/S3014
20	LOCK KEEPER	SS	HW-CU6025

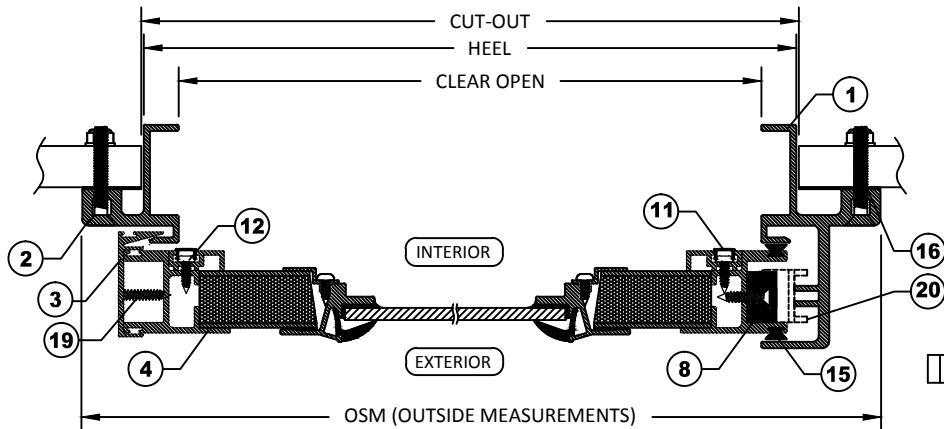

SECTION A-A

STANDARD DIMENSIONS

ID	DESCRIPTION	DIMENSION
A	FLANGE COVERAGE	41mm (1 5/8")
B	EXTERIOR PROTRUSION	77mm (3 1/16")
C	INTERIOR PROTRUSION	31mm (1 1/4")
D	SPIGOT TO CLEAR VIEW	17mm (11/16")
E	FLANGE THICKNESS	18mm (11/16")
F	INSERT THICKNESS	27mm (1 1/16")
G	WINDOW TO DOOR CUT OUT	83mm (3 1/4")
H	WINDOW TO EXTERIOR OF INSERT	78mm (3")

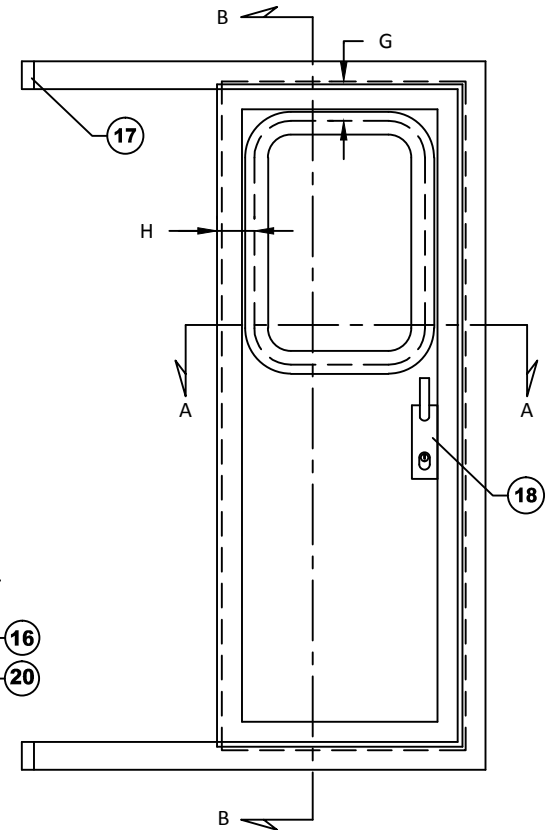

NOTES:

- GENERAL HEEL TOLERANCE +0/-1/4" OVERALL
- AVAILABLE WITH MITERED CORNERS ONLY
- STANDARD MOUNTING HOLES ARE 3/16" WITH #10 COUNTERSUNK ON 8" NOMINAL CENTERS

DRAWING NUMBER

300X

DIAMOND SEA GLAZE MANUFACTURING LTD.
26995 GLOUCESTER WAY, LANGLEY B.C.
CANADA V4W 3Y3
TOLL FREE: 1-800-770-0455
PHONE: 604-607-0091
FAX: 604-607-0092

SCALE

NTS

BY

GG



Diamond Sea Glaze

Crystal Clear. Rock Solid.

ITEM NAME

300X

REVISION

1

ITEM DESCRIPTION

SLIDING OPENING DOOR

ALL DRAWINGS AND ANY ASSOCIATED INFORMATION HEREON CONTAIN PROPRIETARY AND/OR CONFIDENTIAL INFORMATION, AND SHALL NOT BE REPRODUCED, DISCLOSED OR SUBMITTED TO ANY THIRD PARTY WITHOUT PRIOR CONSENT FROM DIAMOND SEA GLAZE MANUFACTURING LTD.