

10. FOR SPECIFIC INFORMATION CONTACT SALES.
9. COMPLETE ASSEMBLY WEIGHT W/ DECK RING, 65.7LBS/ 29.8K.
8. DOGGING PRESSURE FULLY ADJUSTABLE.
7. HANDLE POSITION TOPSIDE INDICATES WHETHER DOGGING MECHANISM IS IN OPEN OR CLOSED POSITION.
6. ALUMINUM ALLOY MECHANISM SHOWN.
5. FLUSH, WATERTIGHT CONSTRUCTION.
4. INTEGRAL TOPSIDE "T" HANDLE STANDARD, OTHER TOPSIDE ACTUATION AVAILABLE.
3. CAST ALUMINUM COVER, MILD STEEL COAMING.
2. QUICK-ACTING, MECHANISM ENGAGES OR DISENGAGES IN QUARTER-TURN OF CENTER SPINDLE.
1. 24.0"/ 610MM DIAMETER CLEAR OPENING, ALL DIMENSIONS SHOWN SUBJECT TO CASTING VARIATION AND ARE REFERENCE ONLY.

NOTES: UNLESS OTHERWISE SPECIFIED.

SPECIFICATIONS SUBJECT TO CHANGE WITHOUT NOTICE.		FREEMAN MARINE EQUIPMENT, INC. 28336 HUNTER CREEK ROAD GOLD BEACH, OR 97444 U.S.A. PHONE: 541-247-7078 FAX: 541-247-2114 www.freemanmarine.com	
UNLESS OTHERWISE SPECIFIED DIMENSIONS ARE IN INCHES, TOLERANCES FOR ROUGH AND CLEAR OPENING ± .125 INCH. ALL OTHERS ARE: .X .XX .XXX ANGLES ±.1 ±.03 ±.010 ±2°		CLIENT: FREEMAN MARINE TITLE: HATCH: 24K, AL COVER, MS RING	
PROJECTION		CONTRACT NO.:	
DO NOT SCALE DRAWING		SCALE: 1:2.5 CALC. WT. ACT. WT. SHEET 1 OF 3	
CONFIDENTIAL PROPERTY OF FREEMAN MARINE EQUIPMENT INC. UNAUTHORIZED USE, COPYING OR DISTRIBUTION IS STRICTLY PROHIBITED. POSSESSOR OF THIS DOCUMENT AGREES TO THE FOREGOING AND SHALL RETURN THIS DOCUMENT UPON REQUEST. © ALL RIGHTS RESERVED 2004		DRAWN: S SNYDER DATE: 7 MAY 09 CHECKED: G. MACEACHERN DATE: 08JUL11 ENGR: DATE:	
REV. DESCRIPTION: DATE: DRAWN		SIZE: D CAGE CODE: 64747 DRAWING NUMBER: 2412-0003 REV. A	

8 7 6 5 4 3 2 1

D

C

B

A

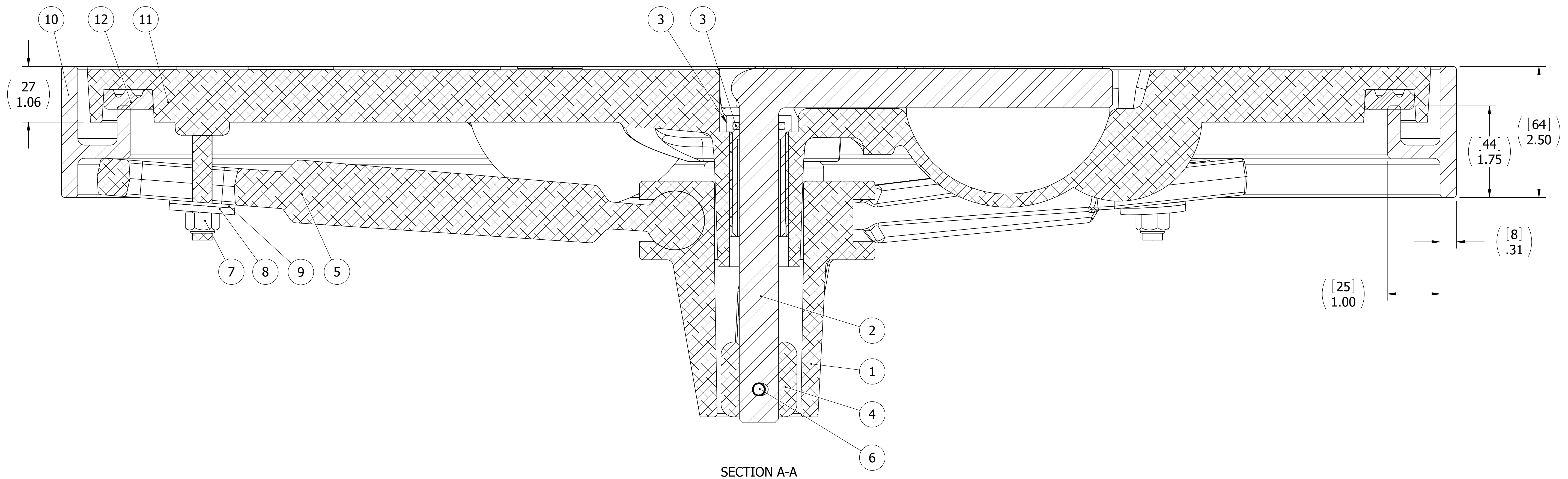

SECTION A-A

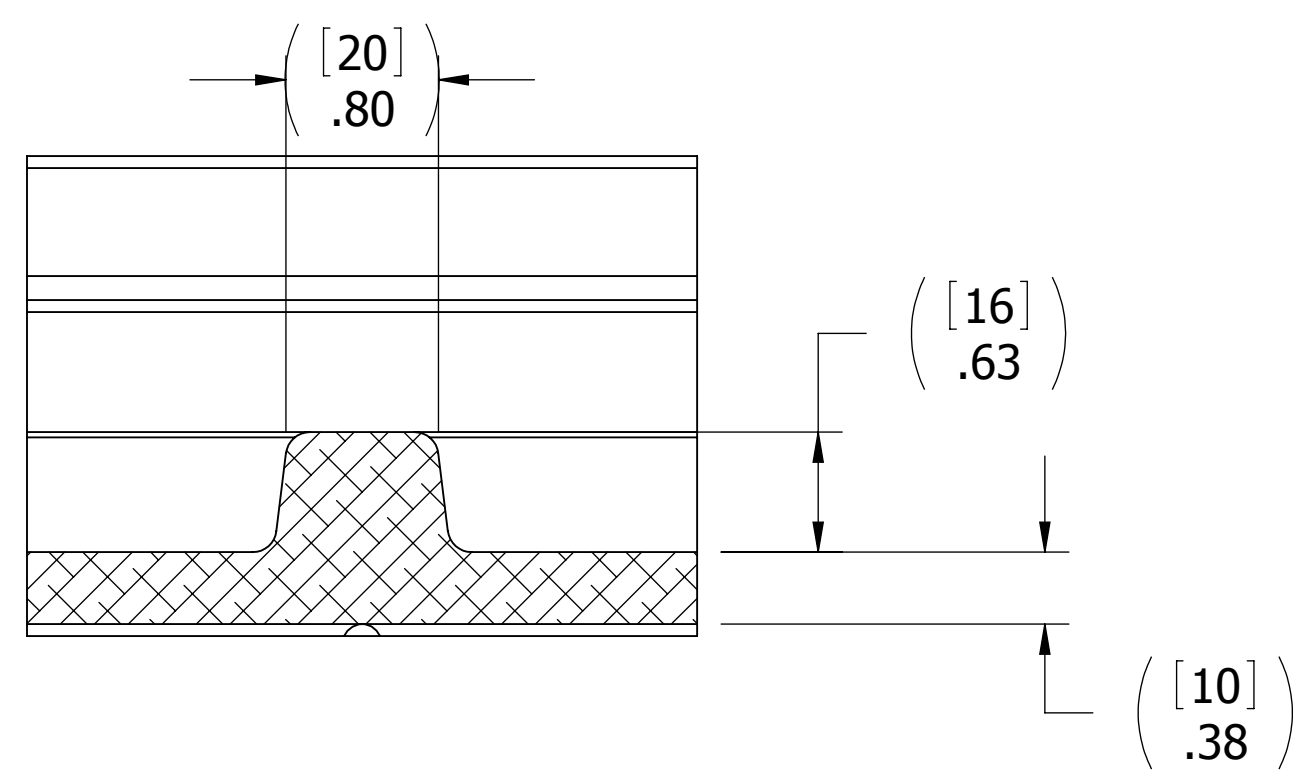

SECTION B-B

ITEM NO.	PART NUMBER	DESCRIPTION	MATERIAL
12	9885-2006	EXTRUSION, GASKET (0631-9885)	NEOPRENE
11	2412-3001	COVER: 24K ALUM, FINISHED CASTING	ALUMINUM, A356
10	2412-1003	24" RING, COAMING	STEEL
9	0413-2005	WASHER, .406 X 1.250 X .062 NYLON	NYLON
8	0411-2033	WASHER, .406 X 1.25 X .125, 316 S/S	STAINLESS STEEL, 316
7	0411-2032	LOCKNUT, NYLON INSERT, 3/8-16, 316 S/S	STAINLESS STEEL, 316
6	0411-2004	PIN, KNURLED, 1/4 X 2-1/4, 316 S/S	STAINLESS STEEL, 316L
5	0211-2012	DOG, LOCKING ARM 24, AL	ALUMINUM, 535.2-F
4	0112-2001	ACTUATOR, AL	ALUMINUM, 535
3	0031-2058	BUSHING ASSY, W/ O-RING, NO SLEEVE	ACETRON/RUBBER
2	0021-2005	HANDLE, S/S, ROUND BAR	STAINLESS STEEL, 316
1	0011-2002	HUB, AL, 4 HOLE	ALUMINUM, 535.2-F

REV.	DESCRIPTION	DATE	DRAWN
-	INITIAL RELEASE	7 MAY 09	SAS
A	UPDATE GEN NOTES AND B.O.M.	08JUL11	PPC

SPECIFICATIONS SUBJECT TO CHANGE WITHOUT NOTICE.

PROJECTION

UNLESS OTHERWISE SPECIFIED DIMENSIONS ARE IN INCHES, TOLERANCES FOR ROUGH AND CLEAR OPENING ± .125 INCH. ALL OTHERS ARE:

.X	.XX	.XXX	ANGLES
±.1	±.03	±.010	±2°

DO NOT SCALE DRAWING

FREEMAN MARINE EQUIPMENT, INC.

28336 HUNTER CREEK ROAD
GOLD BEACH, OR 97444 U.S.A.
PHONE: 541-247-7078 FAX: 541-247-2114
www.freemanmarine.com

CLIENT: FREEMAN MARINE

TITLE: HATCH: 24K, AL COVER, MS RING

SIZE: D CAGE CODE: 64747 DRAWING NUMBER: 2412-0003 REV. A

SCALE: 1:1 CALC. WT. ACT. WT. SHEET 2 OF 3

8

7

6

5

4

3

2

1

D

C

B

A

([683])
Ø 26.88

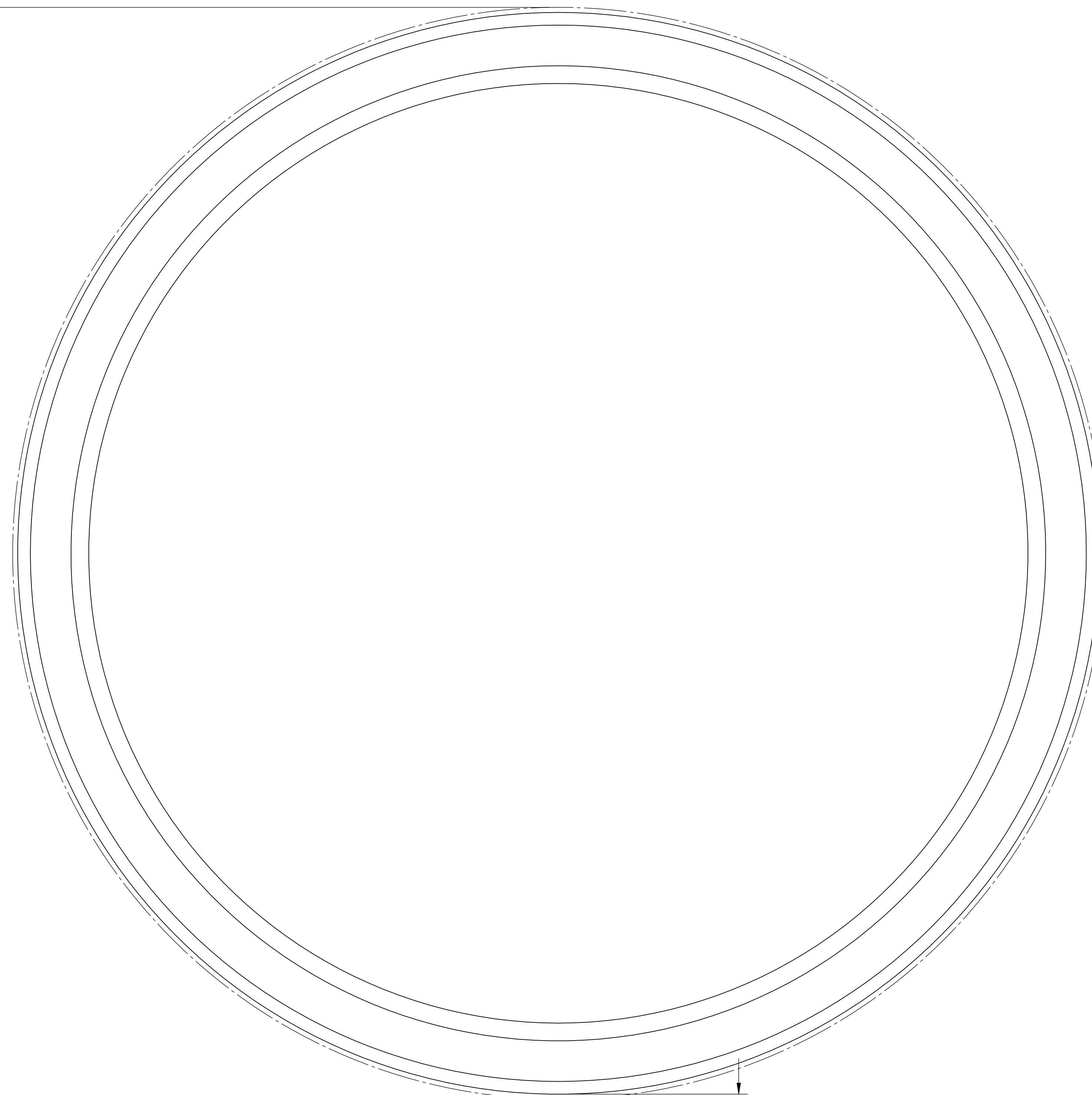

DECK CUT OUT

([3])
.13

- 3. FINISH: 125 RMS MAX.
- 2. BREAK SHARP EDGES AND DEBURR.
- 1. MATERIAL:

NOTES: UNLESS OTHERWISE SPECIFIED.

CUSTOMER APPROVAL

Signature: _____
Date: _____

IMPORTANT! THIS DRAWING SUPERSEDES ALL OTHER DOCUMENTS. By signing this approval you accept and agree that the dimensions and details shown are correct and properly fit your application, regardless of any differences between this drawing and any contract specifications. Should you see any errors in the drawing, or have any questions, please contact your Freeman Marine sales engineer for clarification.

REV.	DESCRIPTION	DATE	DRAWN
-	INITIAL RELEASE	7 MAY 09	SAS
A	UPDATE GEN NOTES AND B.O.M.	08JUL11	PPC

SPECIFICATIONS SUBJECT TO CHANGE WITHOUT NOTICE.

PROJECTION

UNLESS OTHERWISE SPECIFIED DIMENSIONS ARE IN INCHES, TOLERANCES FOR ROUGH AND CLEAR OPENING ± .125 INCH. ALL OTHERS ARE:

.X	.XX	.XXX	ANGLES
±.1	±.03	±.010	±2°

DO NOT SCALE DRAWING

FREEMAN MARINE EQUIPMENT, INC.

CONFIDENTIAL PROPERTY OF FREEMAN MARINE EQUIPMENT, INC. UNAUTHORIZED USE, REPRODUCTION OR DISTRIBUTION IS STRICTLY PROHIBITED. ALL CODES REMAIN THE PROPERTY OF FREEMAN MARINE EQUIPMENT, INC. AND MUST BE RETURNED UPON REQUEST. © ALL RIGHTS RESERVED 2012, FREEMAN MARINE EQUIPMENT, INC.

28336 HUNTER CREEK ROAD
GOLD BEACH, OR 97444 U.S.A.
PHONE: 541-247-7078 FAX: 541-247-2114
www.freemanmarine.com

CLIENT: **FREEMAN MARINE**

TITLE: **HATCH: 24K, AL COVER, MS RING**

SIZE	CAGE CODE	DRAWING NUMBER	REV.
D	64747	2412-0003	A

SCALE: 1:1.75 CALC. WT. ACT. WT. SHEET 3 OF 3