

EXTERIOR VIEW

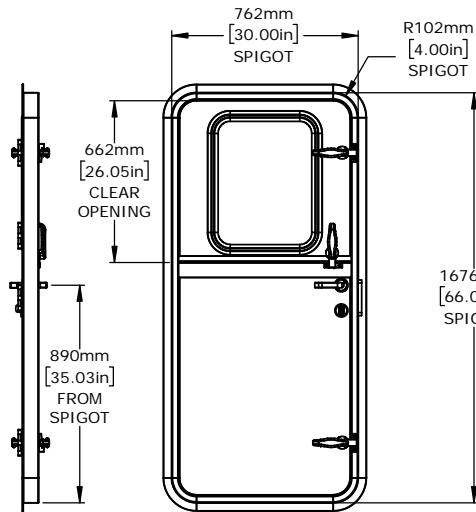

INTERIOR VIEW

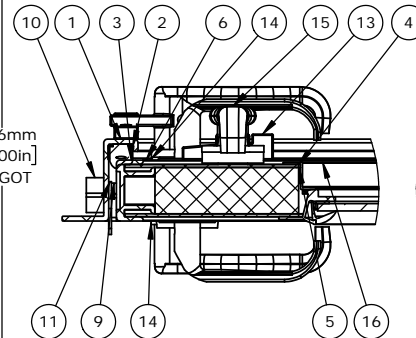

DETAIL B  
SCALE 1 : 4

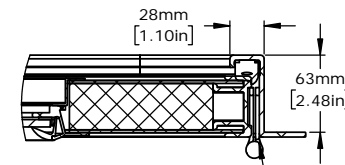

DETAIL C  
SCALE 1 : 4



SECTION A-A

ITEM NO.	PART NUMBER	DESCRIPTION	QTY.
1	D11436	MAIN FRAME	1
2	D10847	GASKET	1
3	D11435	UPPER PANEL EDGE	1
4	D11354	TOP SKIN	2
5	D11481	1-1/2" POLYSTYRENE - TOP	1
6	D11435	LOWER PANEL EDGE	1
7	D11354	BOTTOM SKIN	2
8	D11481	1-1/2" POLYSTYRENE-BOTTOM	1
9	D11234	TRIOVING 5312	1
10	D12015	DEADBOLT RECESS	1
11	D10293	500 STRIKER PLATE	1
12	D10480	4 X 4 SLOTTED HINGE	4
13	D11129	DOG WEDGE	3
14	D11252	DOG, HANDLE, NYLON, SET, 250	2
15	D11270	Nylon 250 Dutch Blind Dog Set - LH	1
16	D5 Window	WINDOW	1

REVISIONS

REV#	DESCRIPTION	DATE

GENERAL NOTES

1. INSTALLATION: BOLT OR WELD-IN.
2. BUILD TO SPIGOT.
3. WEATHERTIGHT CONSTRUCTION.
4. GLASS SHALL BE 1/4" CLEAR TEMPERED.
5. APPROXIMATE WEIGHT 70.3KG (115LBS)
6. FINISH: BARE ALUMINUM.
7. FOR ADDITIONAL INFORMATION CONTACT YOUR SALES REPRESENTATIVE OR PROJECT MANAGER.

CUSTOMER APPROVAL

IMPORTANT! THIS DRAWING SUPERSEDES ALL OTHER DOCUMENTS. BY SIGNING THIS APPROVAL YOU ACCEPT AND AGREE THAT THE DIMENSIONS AND DETAILS SHOWN ARE CORRECT AND PROPERLY FIT YOUR APPLICATION, REGARDLESS OF ANY DIFFERENCES BETWEEN THIS DRAWING AND ANY PRIOR CONTRACT SPECIFICATIONS. SHOULD YOU HAVE ANY QUESTIONS OR SEE ANY ERRORS, DO NOT SIGN THIS APPROVAL UNTIL THE DRAWING IS CORRECTED.

SIGN \_\_\_\_\_ DATE \_\_\_\_\_

UNLESS OTHERWISE SPECIFIED, DIMENSIONS ARE IN MILLIMETERS. TOLERANCES FOR ROUGH AND CLEAR OPENINGS ARE ±3mm (.125"). ALL OTHERS ARE:

METRIC	X	.X	.XX	ANGLES
	±2.5	±.8	±.25	±2°
IMPERIAL	.X	.XX	.XXX	ANGLES
	±.1	±.03	±.010	±2°

BAR CODE \_\_\_\_\_ CAGE CODE \_\_\_\_\_



COPYRIGHT 2015 ADVANTEC GLOBAL INNOVATIONS. ALL RIGHTS RESERVED. CONFIDENTIAL PROPERTY OF ADVANTEC GLOBAL INNOVATIONS. UNAUTHORIZED USE, REPRODUCTION OR DISTRIBUTION IS STRICTLY PROHIBITED. COPIES REMAIN THE PROPERTY OF ADVANTEC GLOBAL INNOVATIONS AND MUST BE RETURNED UPON REQUEST.

CLIENT \_\_\_\_\_

PROJECT TITLE \_\_\_\_\_

WEATHERTIGHT DUTCH DOOR

DWG TITLE MODEL 30" X 66" RH QTY \_\_\_\_\_

SCALE 1:20 DRAWN \_\_\_\_\_ DATE \_\_\_\_\_ CHECKED \_\_\_\_\_ DATE \_\_\_\_\_ SIZE B

S.O. NO. \_\_\_\_\_ DWG NO. \_\_\_\_\_ SHEET 1 OF 1 REV \_\_\_\_\_

250-DUTCH DOOR