

ITEM NO.	QTY	PART NUMBER	DESCRIPTION	MATERIAL
1	2	0231-2071	STRIKER, WINDOW LOCK	ACETRON GP - BLACK
2	52	0411-2009	WASHER, FLAT, 1/4, SS	STAINLESS STEEL, 316
3	4	0411-2374	SCREW BH A .25-20 X 1IN SS 316	SS 316/316L
4	48	0411-2740	SCREW, BUTTON HEAD, 1/4-20 X 2 S/S	STAINLESS STEEL
5	4	0411-2741	SCREW, BUTTON HEAD, 1/4-20 X 2 1/2 S/S	STAINLESS STEEL
6	4	0413-2001	WASHER, .260 X .500 X .031	NYLON
7	52	0413-2010	WASHER, .265 X .500 X .062	NYLON BLACK
8	1	0437-1023	LATCH	REF. S/A - B.O.M.
9	1	P0003538-004-106	WIPER SEAL	HIGH PILE (0691-2002)
10	1	P0005142-010-101	FRAME	6061-T4 (0611-9026)
11	1	P0005142-010-102	1/2" SPACER/RETAINER	BAR, FLAT, 1/2 X 1-1/4, 6063-T52, 16FT (0611-9694)
12	1	P0005142-010-103	RETAINER	6061-T4 (0611-9026 MODIFIED)
13	1	P0005142-010-104	CENTER MULLION FRAME	BAR, FLAT, 1-1/4 X 2, 6061-T6511, 12 FT (0611-9581)
14	1	P0005142-010-105	CENTER MULLION SPACER/RETAINER	PLATE, .313, 5083-H116 ALUMINUM (0711-2118)
15	1	P0005142-010-107	BUTYL TAPE	RUBBER (0331-2001)
16	1	P0005142-010-108	GASKET	Rubber (0391-2011)
17	1	P0005142-010-110	CENTER MULLION	6061-T4 (MOD 0611-9072)
18	1	P0005142-010-901	GLASS, FIXED WINDOW	3/8" THICK CLEAR TMPD
19	1	P0005142-010-902	GLASS, SLIDING WINDOW	3/8" THICK CLEAR TMPD

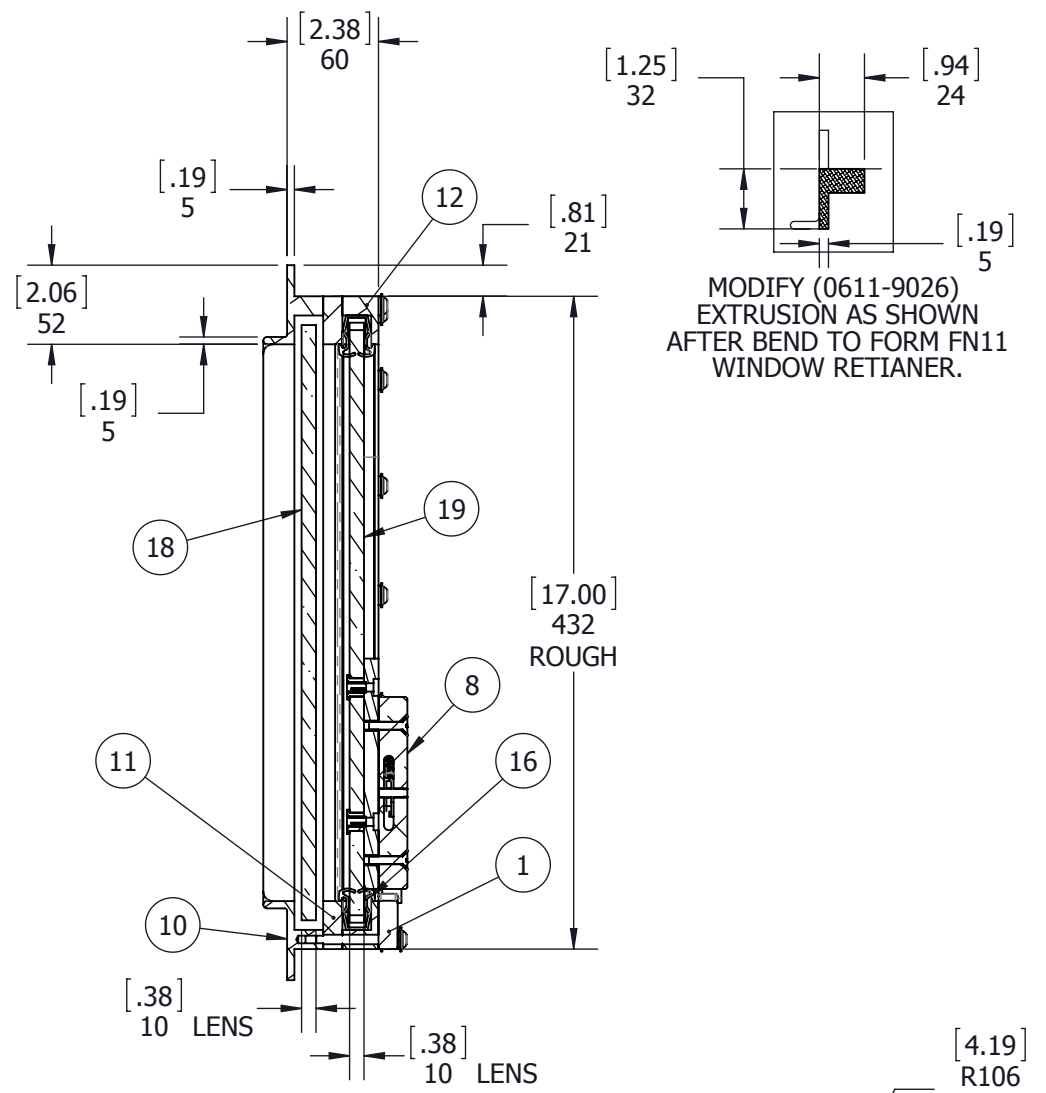

MODIFY (0611-9026) EXTRUSION AS SHOWN AFTER BEND TO FORM FN11 WINDOW RETIANER.

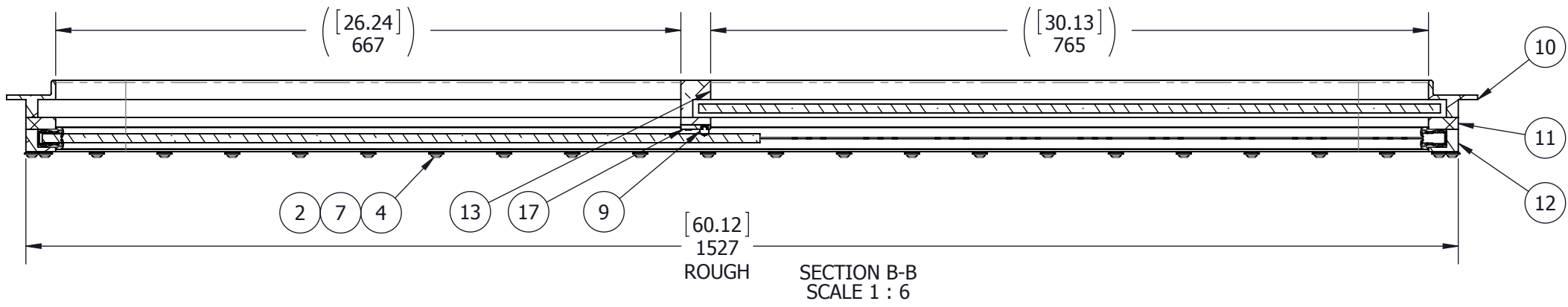
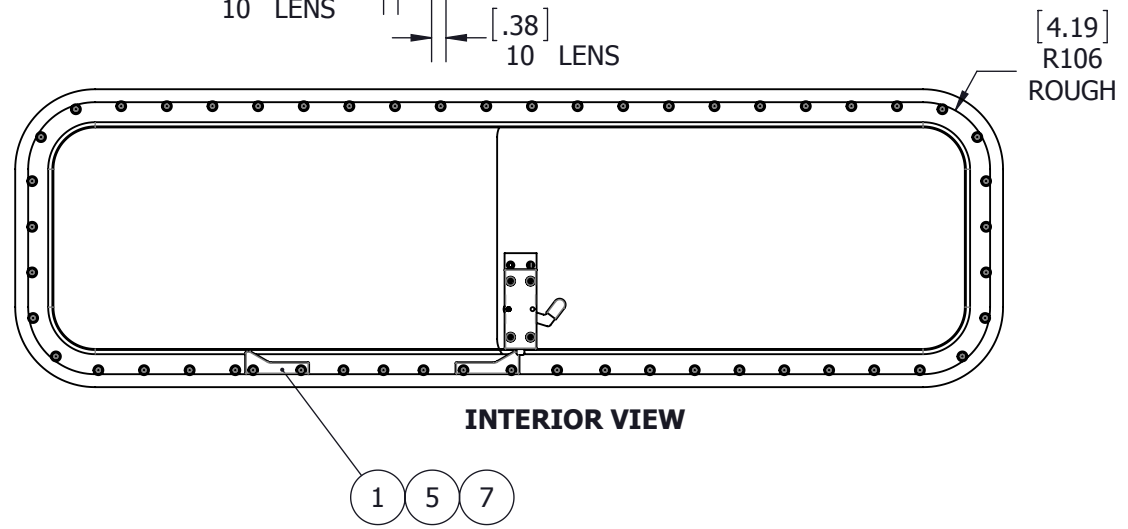
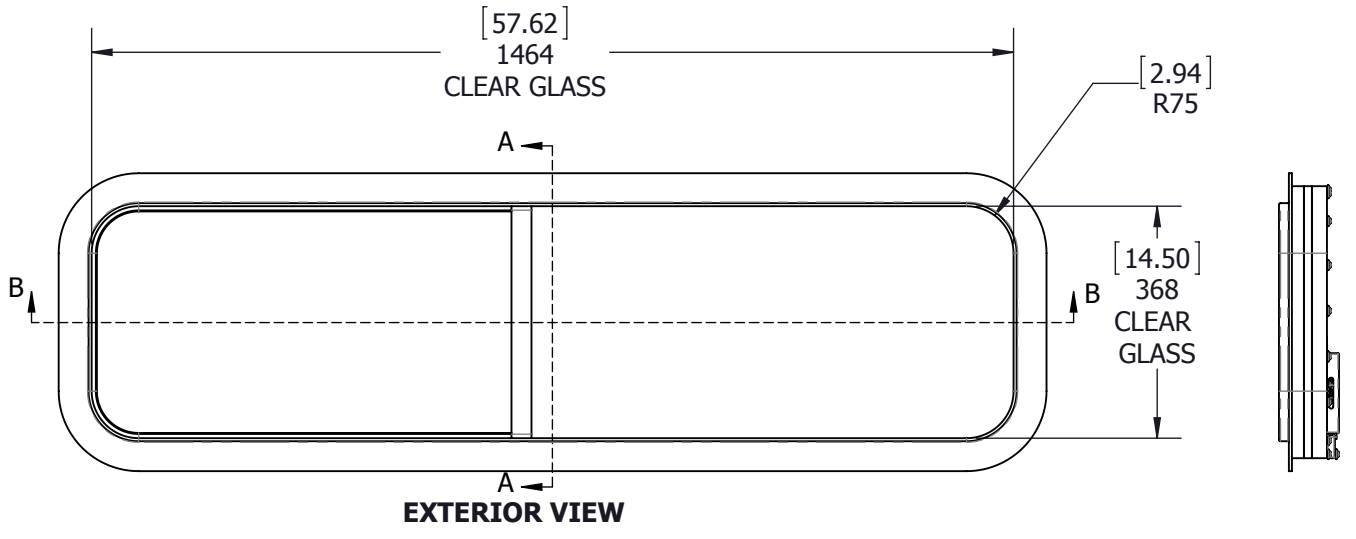

SECTION B-B
SCALE 1 : 6

REVISIONS		
REV	DESCRIPTION	DATE
01	CUSTOMER REVIEW	9/4/14
02	ADDED 432/378 WAS 282/1473 WAS 1451	9/10/14
A	PRODUCTION RELEASE	22SEP14

**GENERAL NOTES
UNLESS OTHERWISE SPECIFIED**

- BREAK SHARP EDGES AND DEBURR

CUSTOMER APPROVAL

IMPORTANT! THIS DRAWING SUPERSEDES ALL OTHER DOCUMENTS. By signing this approval you accept and agree that the dimensions and details shown are correct and properly fit your application, regardless of any differences between this drawing and any contract specifications. Should you see any errors in the drawing, or have any questions, please contact your Freeman Marine sales engineer for clarification.

SIGN	DATE
BAR CODE	CAGE CODE
	64747



COPYRIGHT 2014 ADVANTEC GLOBAL INNOVATIONS. ALL RIGHTS RESERVED. CONFIDENTIAL PROPERTY OF ADVANTEC GLOBAL INNOVATIONS. UNAUTHORIZED USE, REPRODUCTION OR DISTRIBUTION IS STRICTLY PROHIBITED. COPIES REMAIN THE PROPERTY OF ADVANTEC GLOBAL INNOVATIONS AND MUST BE RETURNED UPON REQUEST.

CLIENT					
PROJECT TITLE					
DWG TITLE FREEMAN MODEL 5320 - AFT SLIDER, PORT SIDE ACTIVE					
SCALE	DRAWN BY	DATE	CHECKED BY	DATE	SHEET
1:12	P HENDRICKSON	4-Sep-14	ZLC	9/4/14	1 of 1
S.O. NO	DWG NO	QTY	REV		
42274	P0005142-010	1	A		