

FREEMAN MARINE'S Dual-Axis sliding doors with a patented camming mechanism\*\* and full perimeter elastomer gasket provide excellent performance when aggressive spray and splashed weather tight sealing is required. Sliding doors can be specified in virtually any size required and a variety of configurations; single panel, bi-parting, and multi-panel styles. Custom sized windows designed to complement adjacent vessel windows can be ordered. Passive solid panels as well as sidelights are also available.

FREEMAN MARINE Sliding doors are finished in yacht-quality linear polyurethane and offer attention to detail, durability, performance and style not found in ordinary sliding doors. Typical installations:

- Pilothouse • Galley • Salon Entry

**DUAL-AXIS DESIGN FEATURES**

- Full Perimeter Elastomer Gasket
- Cam-Actuated\*\* Weather Tight Sealing
- Precision Crafted Panels
- Quality Latches and Hardware
- Custom Sized Windows
- Flat, Curved and Knuckle Panels
- Single, Bi-Parting Doors
- Automatic Operation (avail)

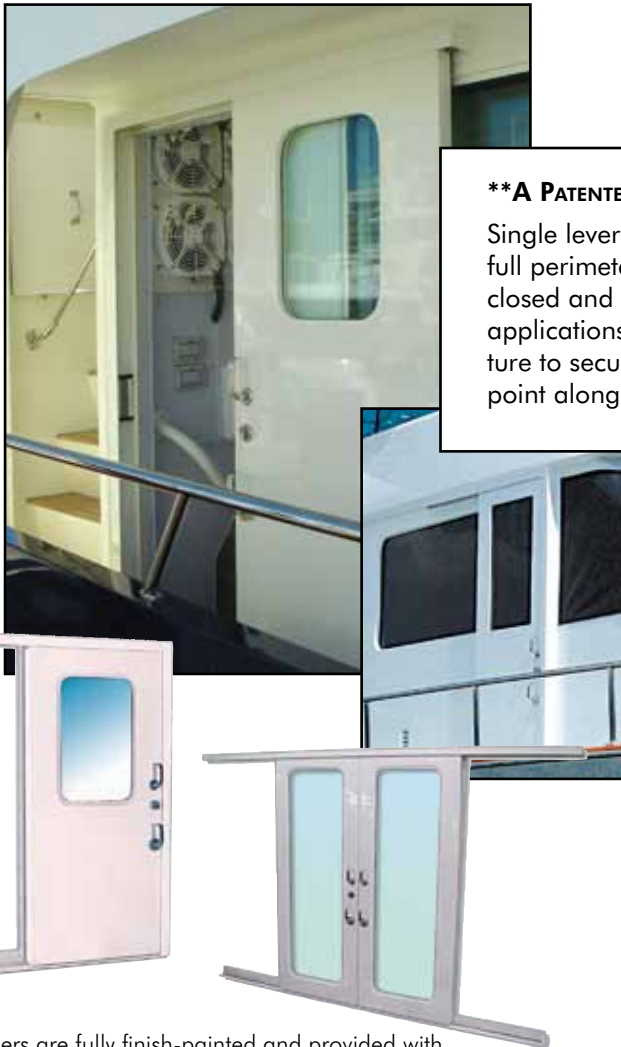

**\*\*A PATENTED DESIGN EXCLUSIVELY FROM FREEMAN MARINE**  
Single lever actuated mechanism creates a weather tight, full perimeter, positive gasket seal when the door is fully closed and "cammed-in." Ideal for both exterior and interior applications, camming ability also acts as a hold open feature to secure the door panel in a stationary position at any point along its track. USA Patent #5,542,213

**FREEMAN MARINE DUAL AXIS SLIDING DOOR**

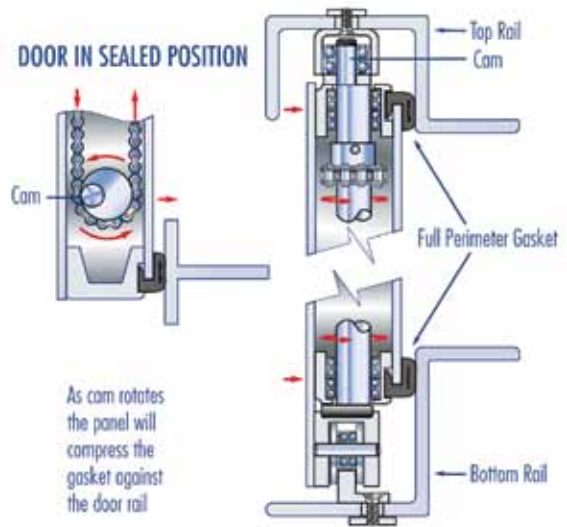

Most sliders are fully finish-painted and provided with windows and operation hardware per customer's specification. Note separate operating handles for the locksets and the internal camming mechanism.



Aft cockpit access,  
Open



Installed side view,  
Closed window alignment



1720 with side lite,  
Exterior/ Interior,  
Two-Tone Paint

Automatic  
drive detail



Counterpull  
detail



Adjustable  
Lower rail,  
Close-up



Track,  
Panel and  
center  
mullion detail



Striker plate  
assembly,  
Bumper strips  
cushion  
closing door



Stop door,  
Upper  
guide rail



Full glass, Mitered  
corners, Painted to  
match windows



Pilot house,  
Mitered window,  
Paint to match windows



Inside view,  
In fit-up station



Side entry, Radius  
corner window and  
sidelight



Aft access, Closed



Pilot access,  
Interior



Bi-parting, Sidelights,  
Installed



Side access, Open

Two sets of handles,  
Top for latching,  
Bottom to cam  
door in and out  
against gasket



Track panel and  
mullion detail,  
Upper



Inside view  
showing gasket  
in final  
assembly fit up



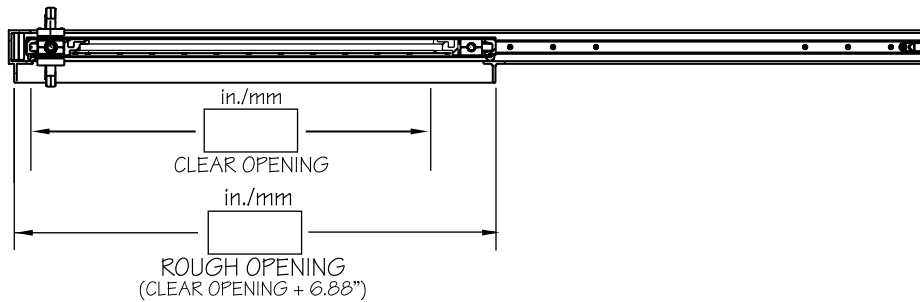
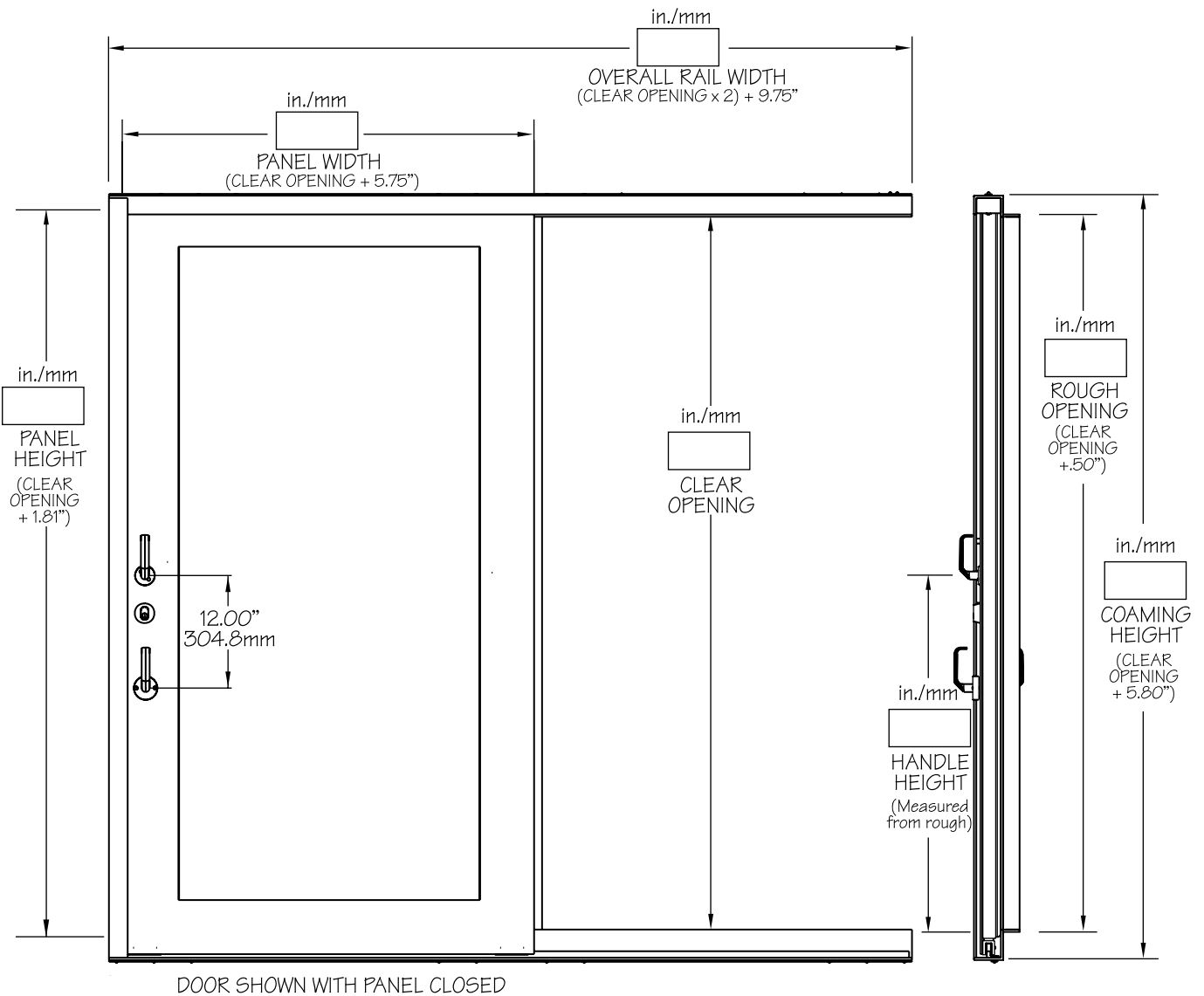

Scale None

© ALL RIGHTS RESERVED  
2010 FREEMAN MARINE EQUIPMENT, INC.  
SPECIFICATIONS SUBJECT TO CHANGE WITHOUT NOTICE

LAYOUT  
MODEL 1720

LAYOUT  
MODEL 1720

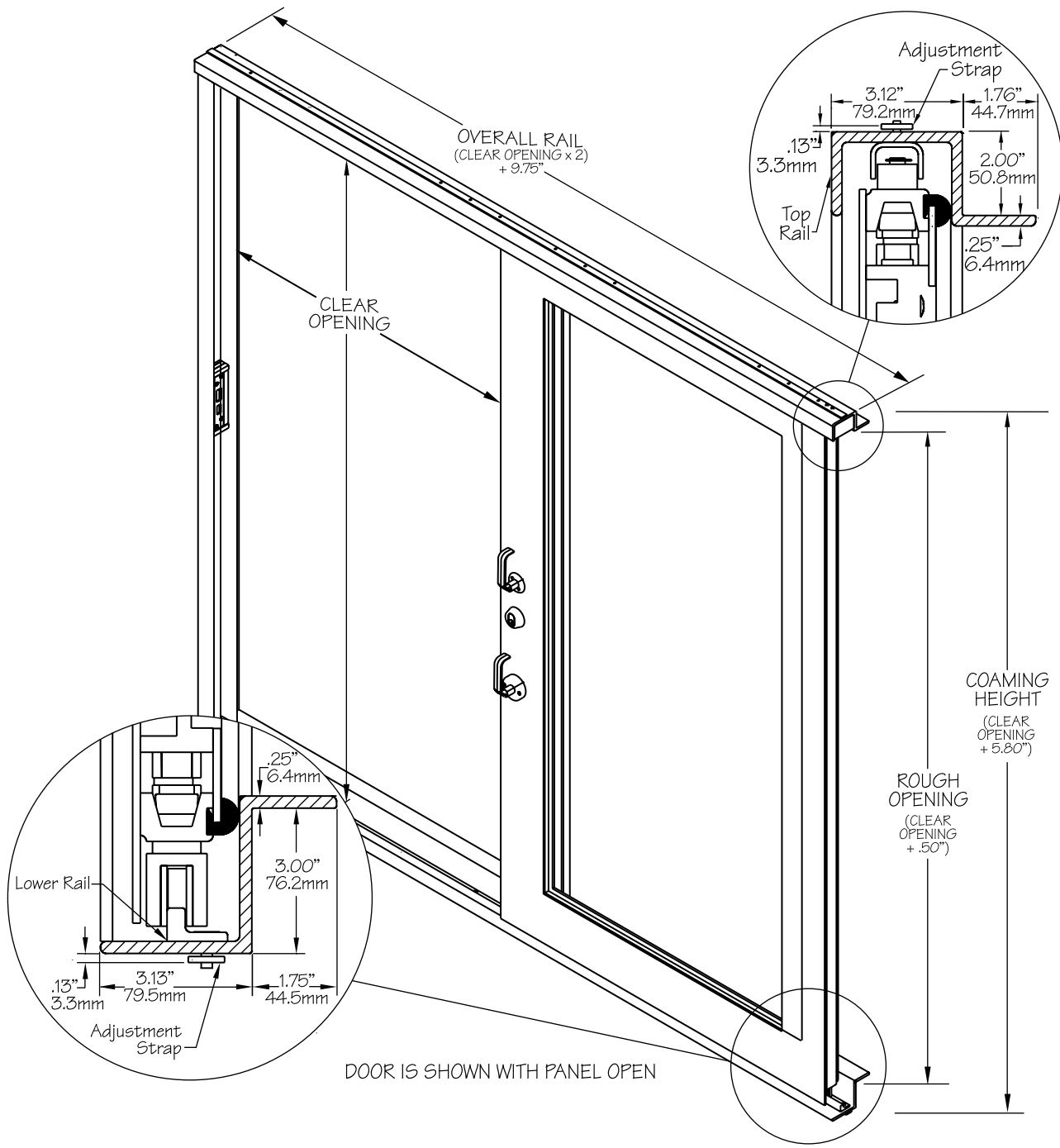

Scale None

© ALL RIGHTS RESERVED  
2010 FREEMAN MARINE EQUIPMENT, INC.  
SPECIFICATIONS SUBJECT TO CHANGE WITHOUT NOTICE

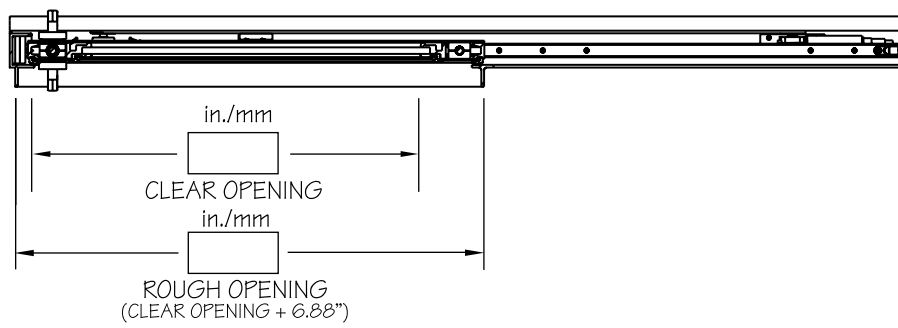
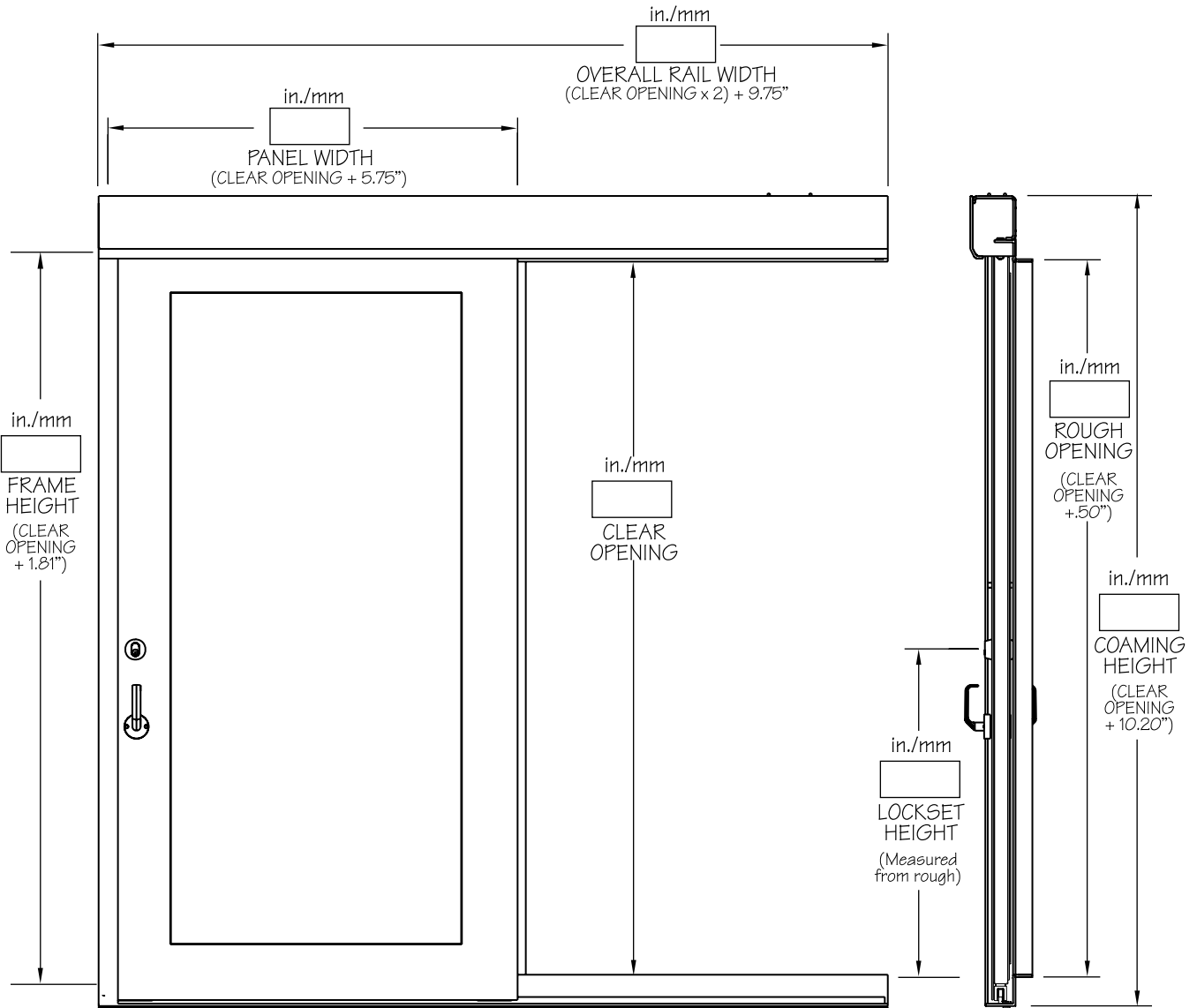

**LAYOUT  
MODEL 1720**

Scale None

© ALL RIGHTS RESERVED  
2010 FREEMAN MARINE EQUIPMENT, INC.  
SPECIFICATIONS SUBJECT TO CHANGE WITHOUT NOTICE

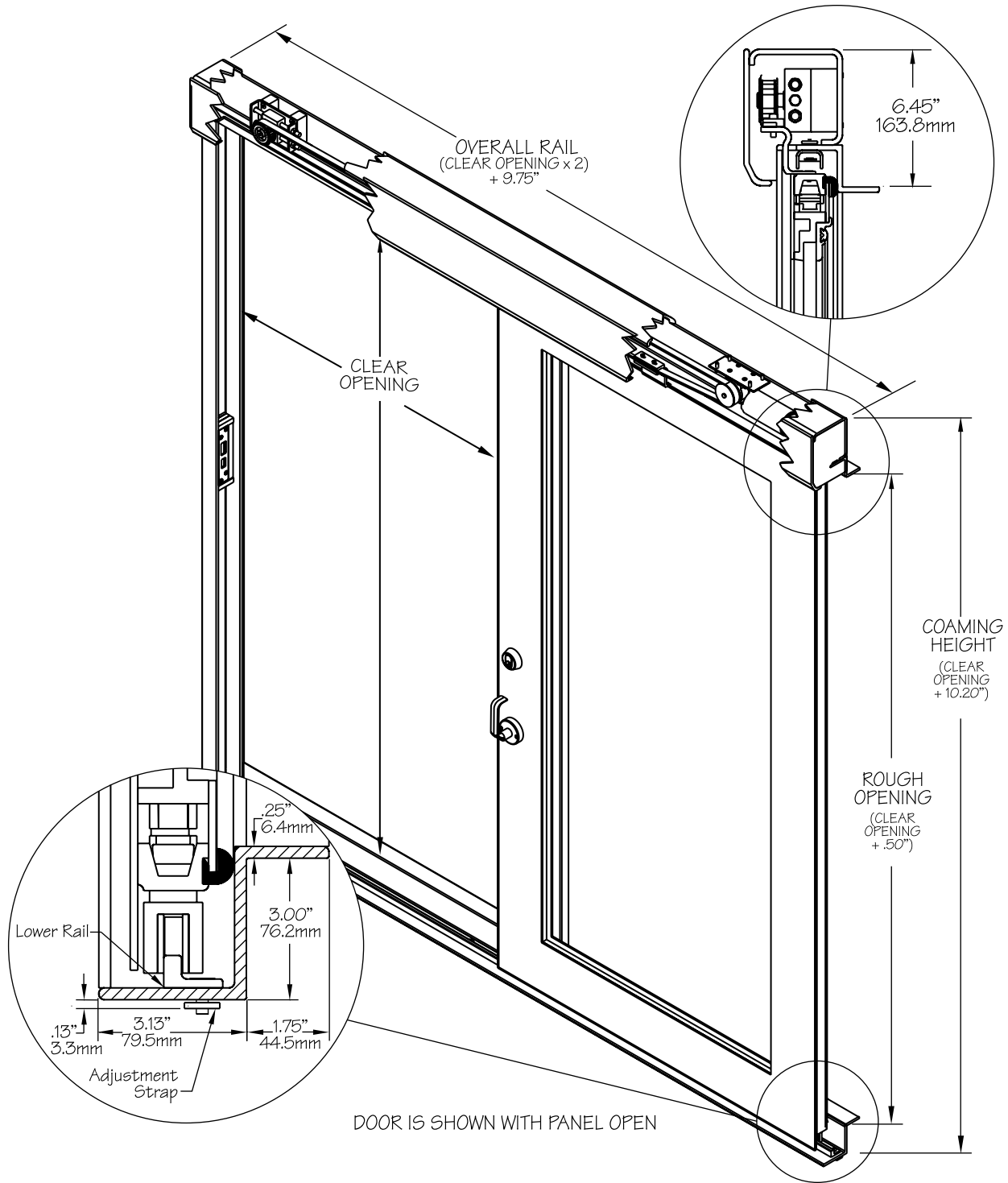

LAYOUT  
MODEL 1720

Scale None

© ALL RIGHTS RESERVED  
2010 FREEMAN MARINE EQUIPMENT, INC.  
SPECIFICATIONS SUBJECT TO CHANGE WITHOUT NOTICE

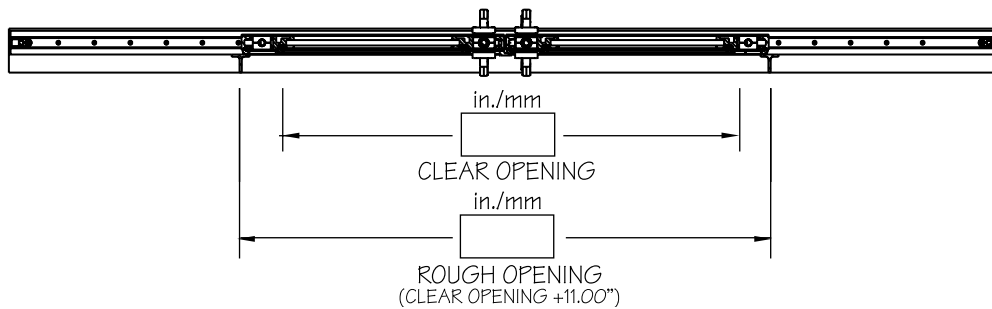
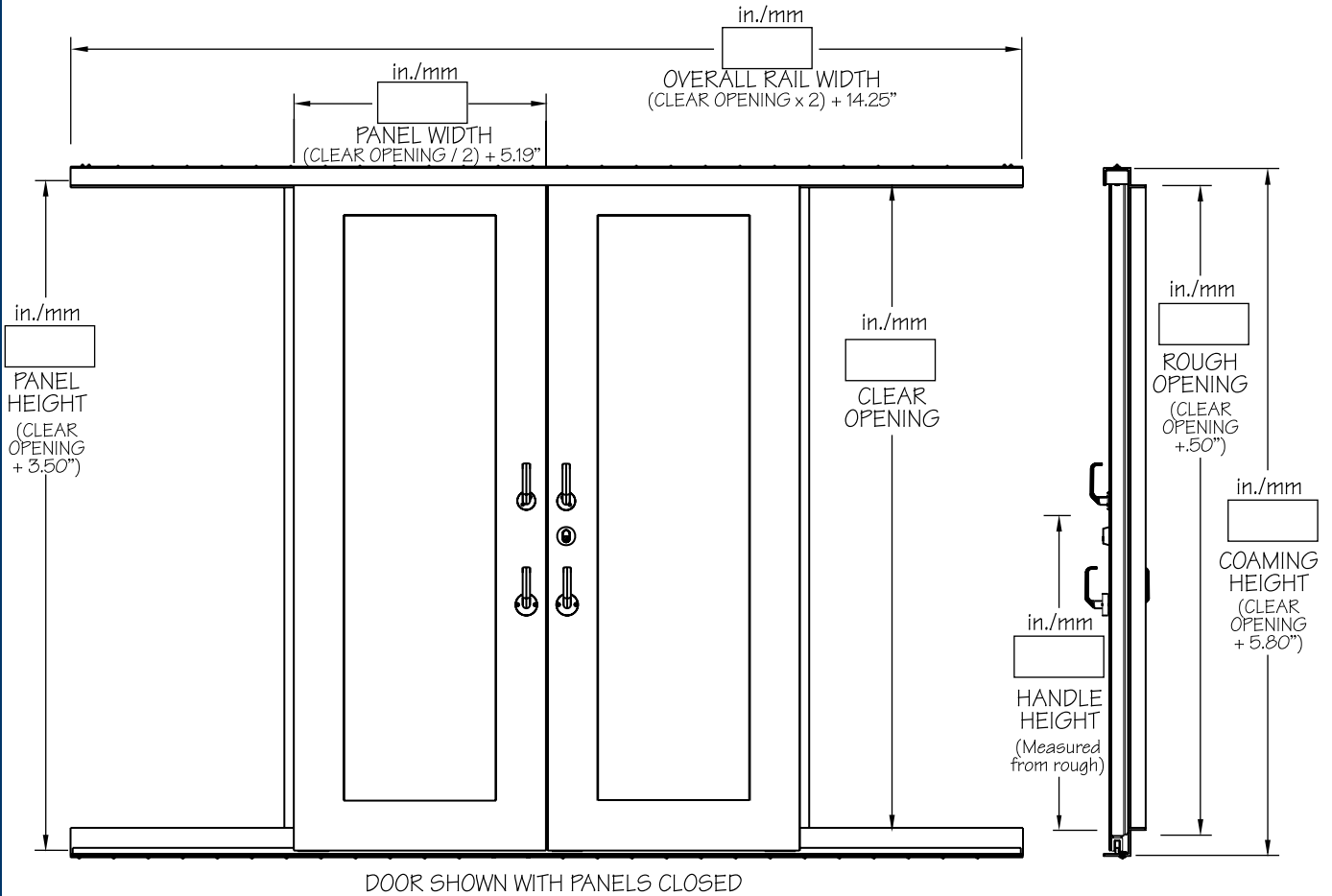

LAYOUT  
MODEL 1726

Scale	None
-------	------

© ALL RIGHTS RESERVED  
2010 FREEMAN MARINE EQUIPMENT, INC.  
SPECIFICATIONS SUBJECT TO CHANGE WITHOUT NOTICE



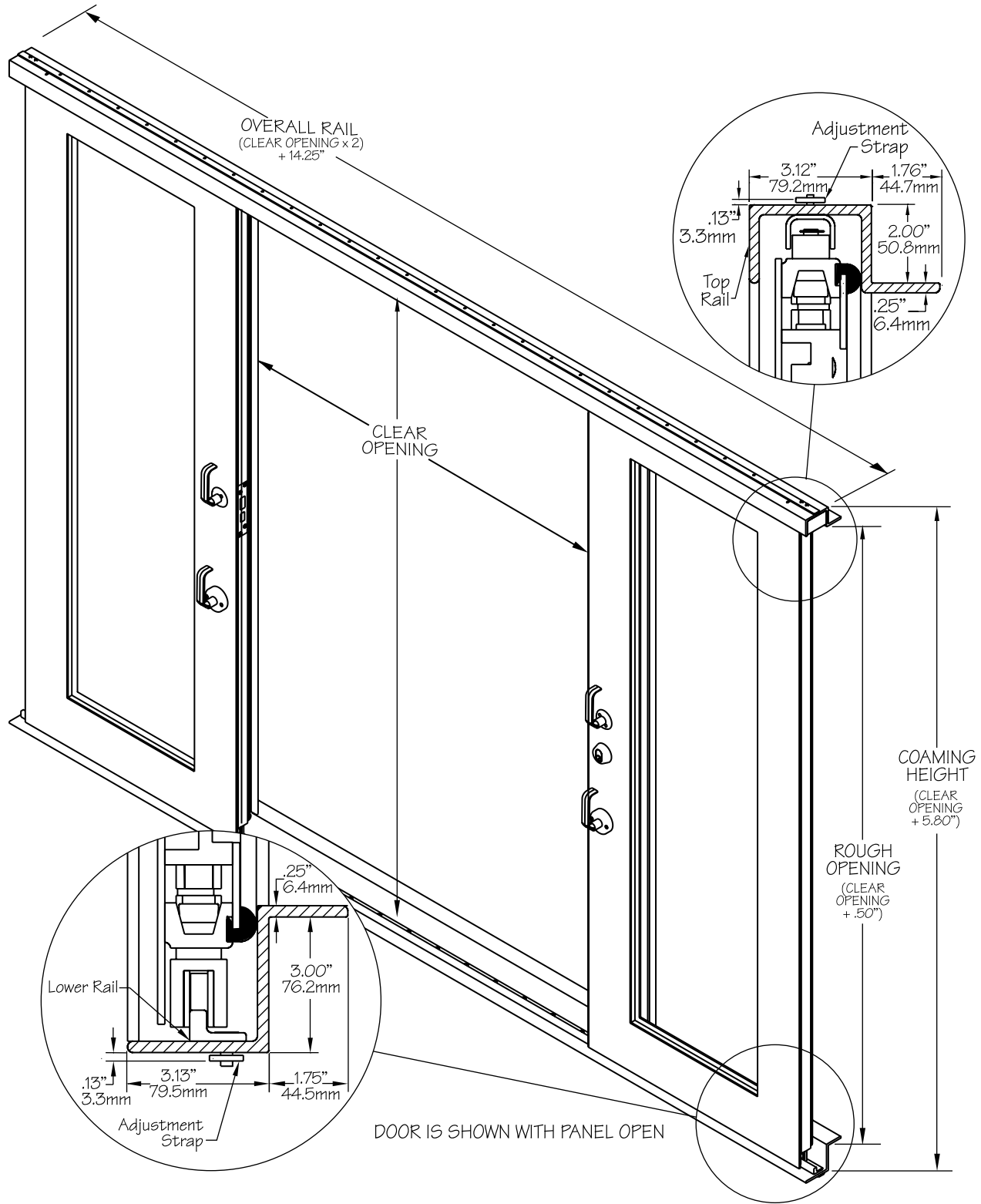

LAYOUT  
MODEL 1726

Scale None

© ALL RIGHTS RESERVED  
2010 FREEMAN MARINE EQUIPMENT, INC.  
SPECIFICATIONS SUBJECT TO CHANGE WITHOUT NOTICE



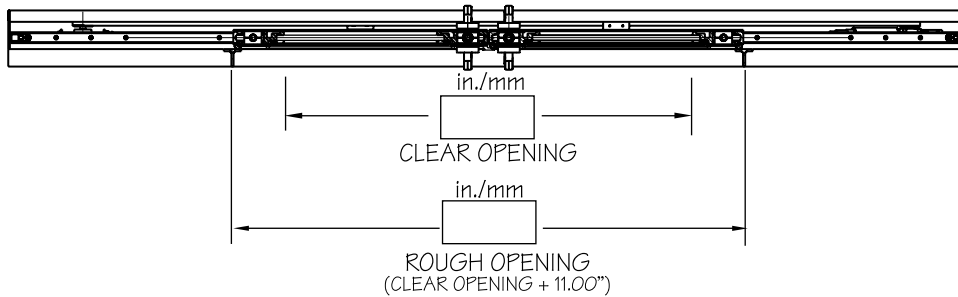
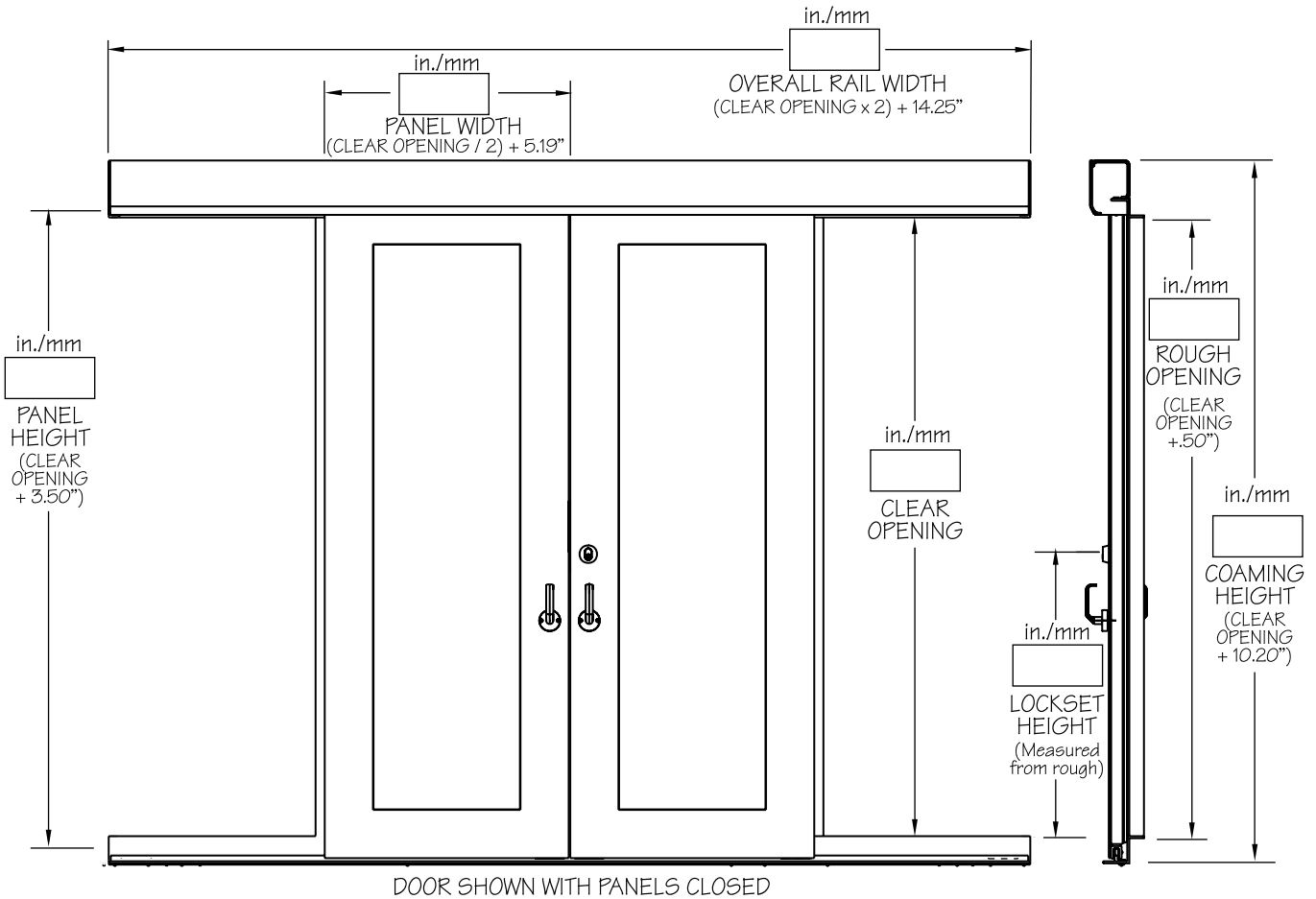

**LAYOUT  
MODEL 1726**

<b>Scale</b>	None
--------------	------

© ALL RIGHTS RESERVED  
2010 FREEMAN MARINE EQUIPMENT, INC.  
SPECIFICATIONS SUBJECT TO CHANGE WITHOUT NOTICE

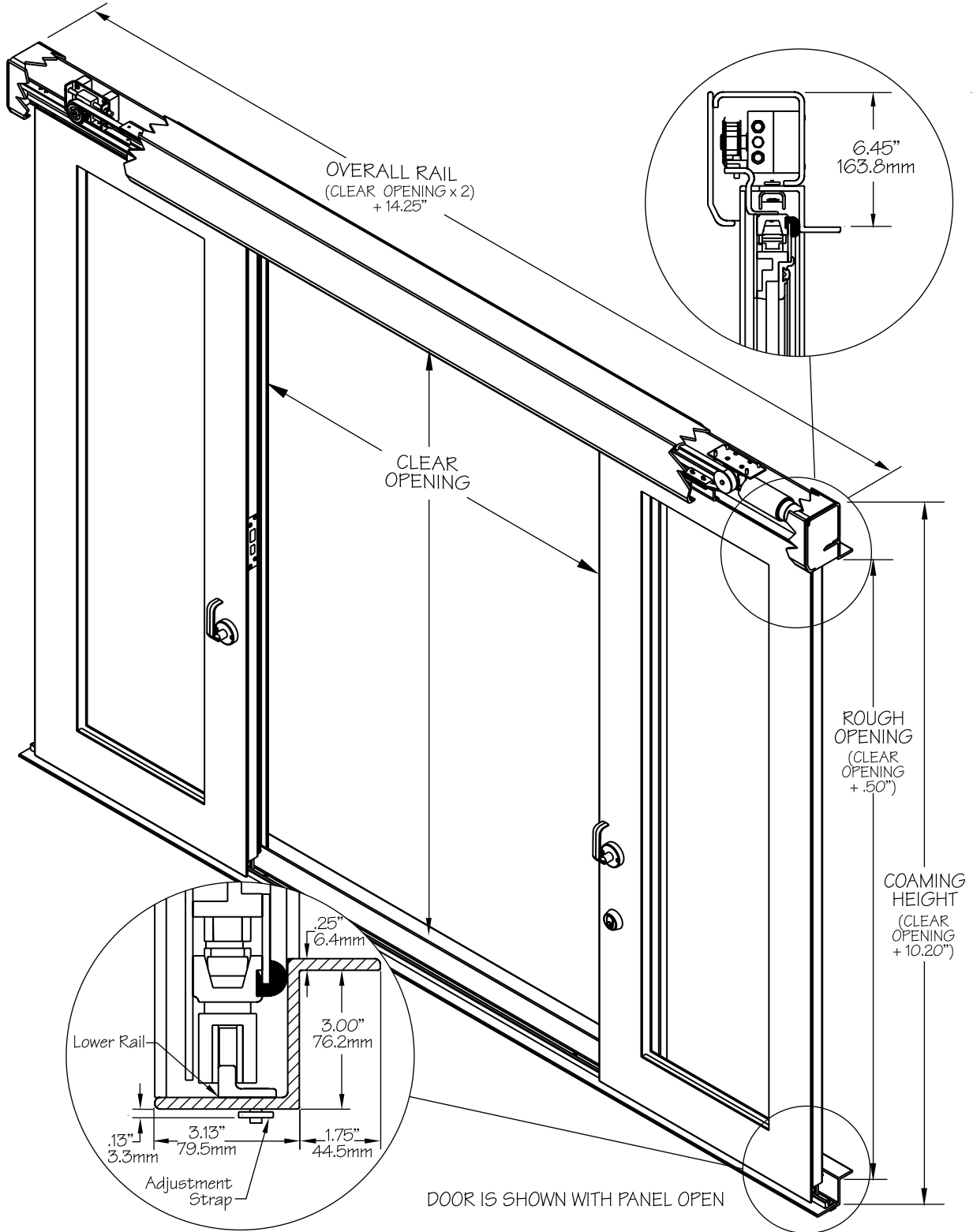

LAYOUT  
MODEL 1726

Scale None

© ALL RIGHTS RESERVED  
2010 FREEMAN MARINE EQUIPMENT, INC.  
SPECIFICATIONS SUBJECT TO CHANGE WITHOUT NOTICE