

PLAN

SCHEDULE OF MATERIALS		
PC.	MATERIAL	REMARKS
1	STEEL	
2	PLATED	
3	PLATED	
4	MILD STEEL	
5	STEEL	
6	STEEL	
7	STEEL	
8	NEOPRENE	

DIMENSION SCHEDULE									
CLEAR OPENING	A	B	C	D	E	F	G	H	I
15" X 23"	23"	24-3/4"	27"	29"	15"	16-3/4"	19"	21"	8"
18" X 24"	24"	25-3/4"	28"	30"	18"	19-3/4"	22"	24"	6"

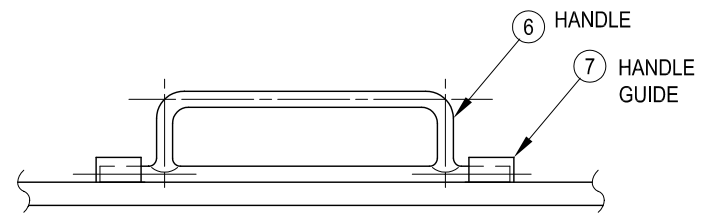

HANDLE DETAIL

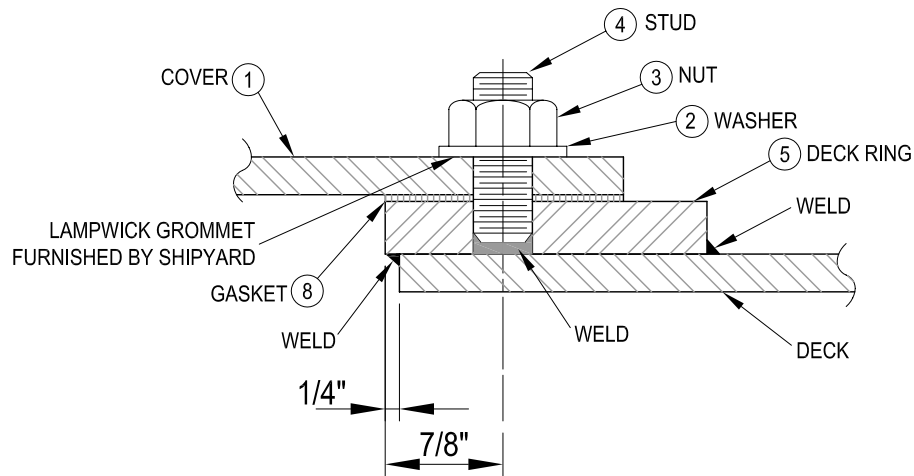

STUD DETAIL

Freeman Marine Equipment
 Gold Beach, Oregon
 BOLTED PLATE MANHOLE W/STUDS
 DWG. NO.: 309-MS