

PLAN

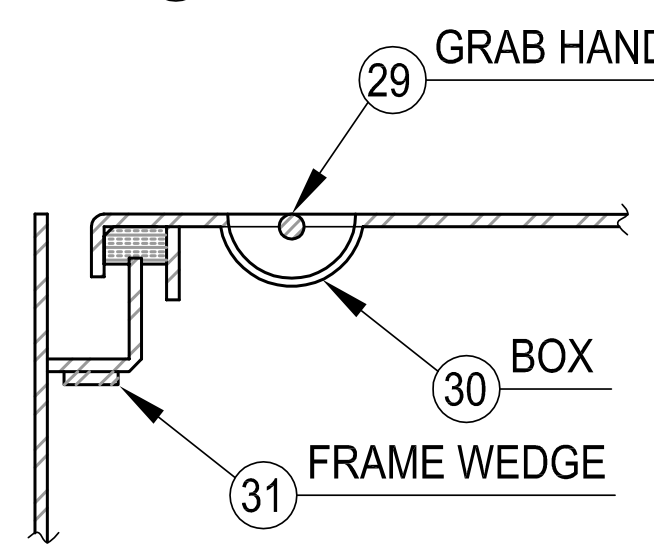

HANDLE DETAIL

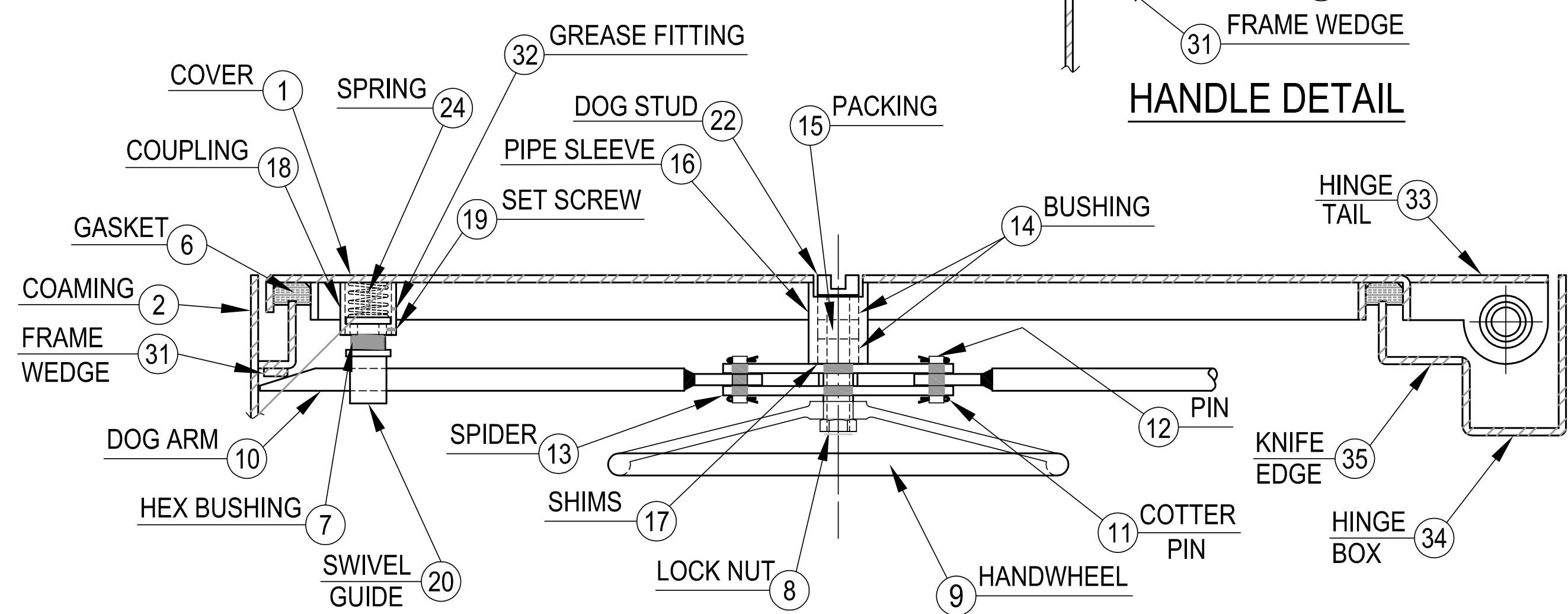

SECTION

SCHEDULE OF MATERIALS

| PC. | MATERIAL | REMARKS |
|-----|--------------|---------|
| 1 | MILD STEEL | |
| 2 | MILD STEEL | |
| 3 | MILD STEEL | |
| 4 | COLD FINISH | |
| 5 | STEEL | |
| 6 | NEOPRENE | |
| 7 | BRASS | |
| 8 | PLATED STEEL | |
| 9 | MILD STEEL | |
| 10 | MILD STEEL | |
| 11 | STAINLESS | |
| 12 | BRASS | |
| 13 | MILD STEEL | |
| 14 | DELRIN | |
| 15 | TEFLON | |
| 16 | MILD STEEL | |
| 17 | STAINLESS | |
| 18 | MILD STEEL | |
| 19 | PLATED STEEL | |
| 20 | BRASS | |
| 21 | STAINLESS | |
| 22 | BRASS | |
| 23 | MILD STEEL | |
| 24 | PLATED STEEL | |
| 25 | SPRING STEEL | |
| 26 | MILD STEEL | |
| 27 | MILD STEEL | |
| 28 | MILD STEEL | |
| 29 | MILD STEEL | |
| 30 | MILD STEEL | |
| 31 | MILD STEEL | |
| 32 | PLATED STEEL | |
| 33 | MILD STEEL | |
| 34 | MILD STEEL | |
| 35 | MILD STEEL | |

D
C
B
A

NOTES: UNLESS OTHERWISE SPECIFIED.

CUSTOMER APPROVAL
Signature: _____
Date: _____
IMPORTANT! THIS DRAWING SUPERSEDES ALL OTHER DOCUMENTS. By signing this approval you accept and agree that the dimensions and details shown are correct and properly fit your application, regardless of any differences between this drawing and any contract specifications. Should you see any errors in the drawing, or have any questions, please contact your Freeman Marine sales engineer for clarification.

| | |
|--|--------------------------|
| SPECIFICATIONS SUBJECT TO CHANGE WITHOUT NOTICE. | |
| PROJECTION | |
| UNLESS OTHERWISE SPECIFIED DIMENSIONS ARE IN INCHES, TOLERANCES FOR ROUGH AND CLEAR OPENING ± .125 INCH. ALL OTHERS ARE: | |
| .X | .XX .XXX ANGLES |
| ±.1 | ±.03 ±.010 ±.2° |
| DO NOT SCALE DRAWING | |
| 00 | PRODUCTION RELEASE |
| REV. | DESCRIPTION: DATE: DRAWN |

FREEMAN MARINE EQUIPMENT, INC.
28336 HUNTER CREEK ROAD
GOLD BEACH, OR 97444 U.S.A.
PHONE: 541-247-7078 FAX: 541-247-2114
www.freemanmarine.com

CONFIDENTIAL PROPERTY OF FREEMAN MARINE EQUIPMENT, INC. UNAUTHORIZED USE, REPRODUCTION OR DISTRIBUTION IS STRICTLY PROHIBITED. ALL COPIES REMAIN THE PROPERTY OF FREEMAN MARINE EQUIPMENT, INC. AND MUST BE RETURNED UPON REQUEST.

CLIENT: **FREEMAN MARINE**

TITLE: **QUICK ACTING WATERTIGHT FLUSH SCUTTLE**

SIZE: **D** CAGE CODE: **64747** DRAWING NUMBER: **403-MS** REV. **00**

SCALE: 1:5.5 CALC. WT. ACT. WT. SHEET 1 OF 1