

8

7

6

5

4

3

2

1

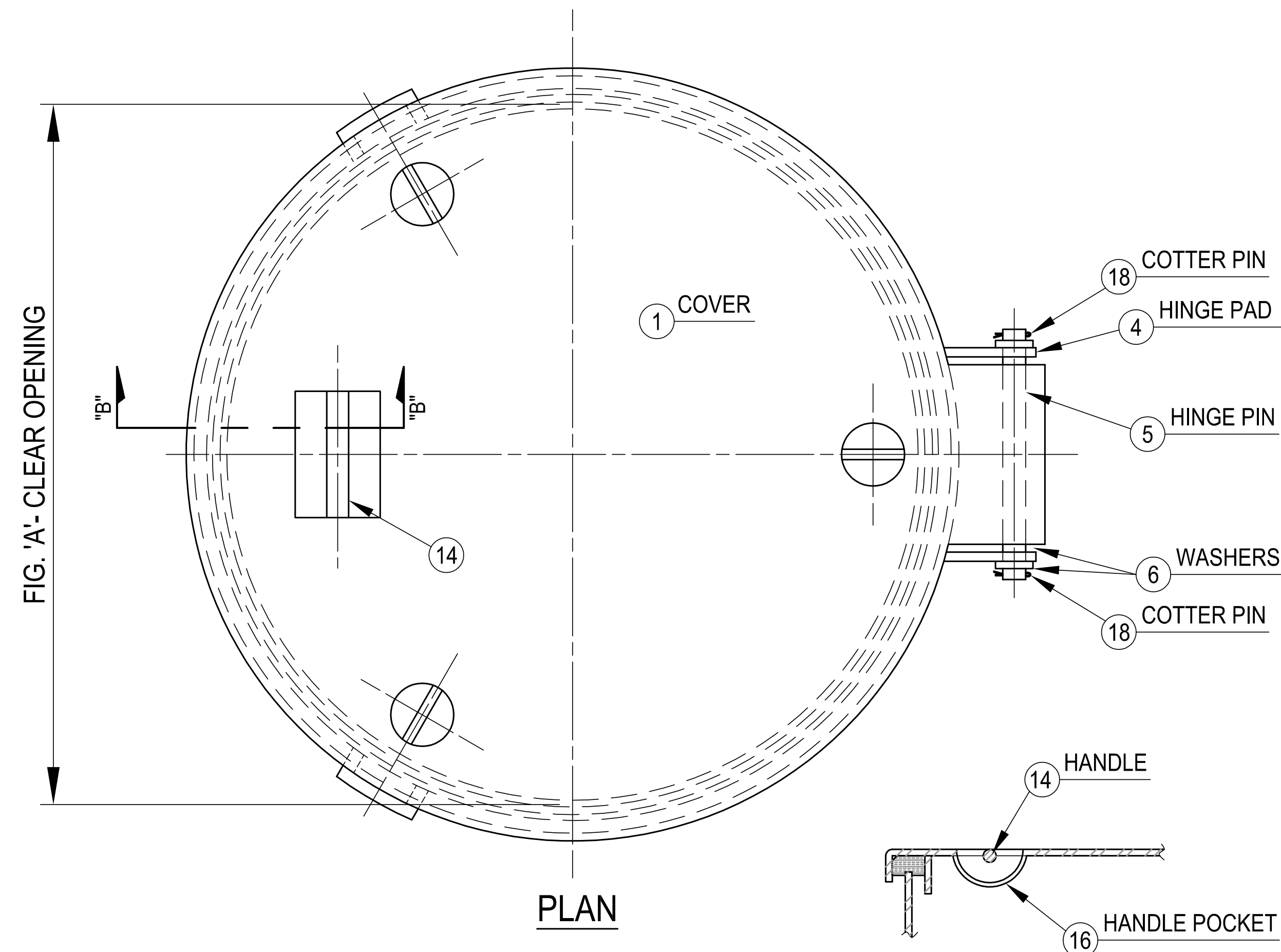

SECTION 'B-B'

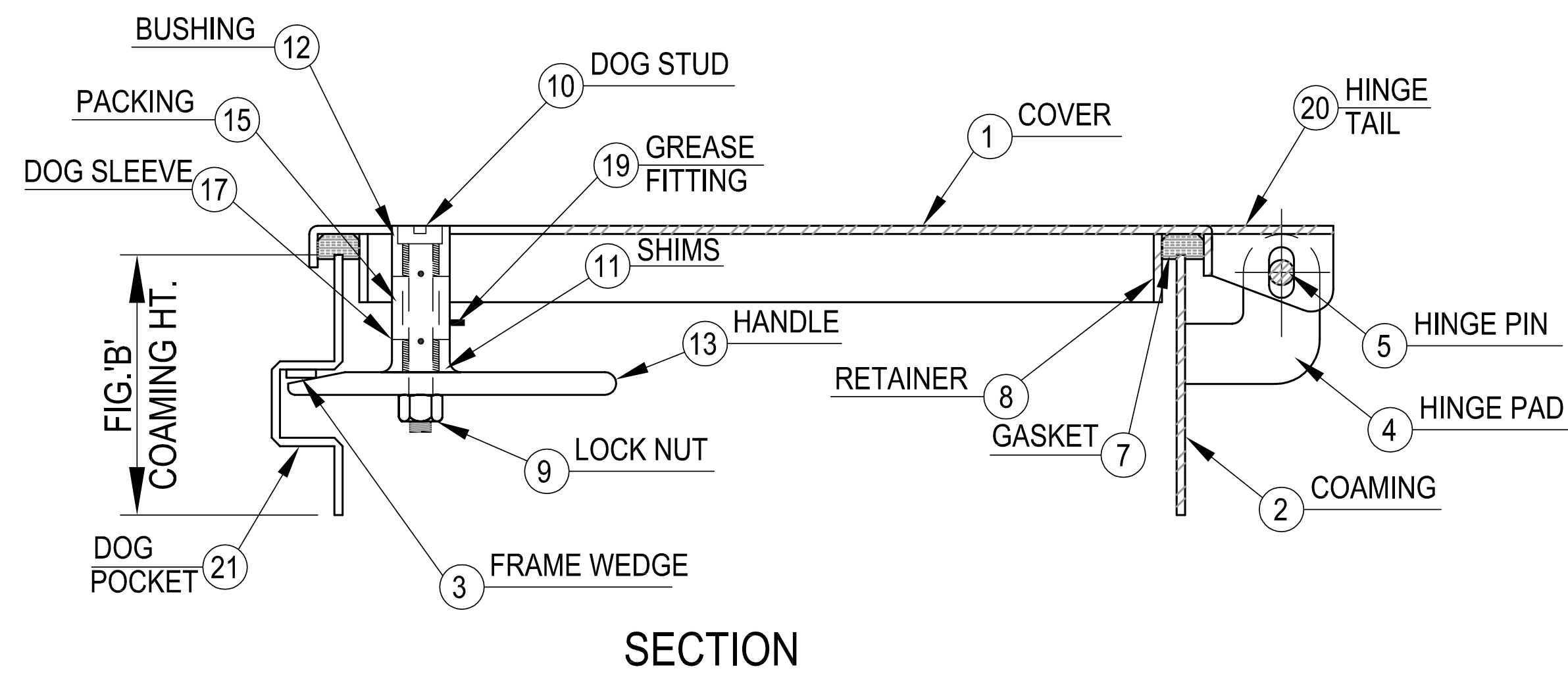

SECTION

| SCHEDULE OF MATERIALS | | |
|-----------------------|------------------|---------|
| PC. | MATERIAL | REMARKS |
| 1 | STEEL | |
| 2 | STEEL | |
| 3 | FORGED STEEL | |
| 4 | STEEL | |
| 5 | COLD FINISH | |
| 6 | STAINLESS | |
| 7 | NEOPRENE | |
| 8 | STEEL | |
| 9 | PLATED STEEL | |
| 10 | BRASS | |
| 11 | STAINLESS | |
| 12 | DELTRIN | |
| 13 | MANGANESE BRONZE | |
| 14 | STEEL | |
| 15 | TEFLON | |
| 16 | STEEL | |
| 17 | STEEL | |
| 18 | STAINLESS | |
| 19 | PLATED STEEL | |
| 20 | STEEL | |
| 21 | STEEL | |

D

C

B

A

NOTES: UNLESS OTHERWISE SPECIFIED.

CUSTOMER APPROVAL

Signature: _____

Date: _____

IMPORTANT! THIS DRAWING SUPERSEDES ALL OTHER DOCUMENTS. By signing this approval you accept and agree that the dimensions and details shown are correct and properly fit your application, regardless of any differences between this drawing and any contract specifications. Should you see any errors in the drawing, or have any questions, please contact your Freeman Marine sales engineer for clarification.

| REV. | DESCRIPTION | DATE | DRAWN |
|------|--------------------|---------|-------|
| 00 | PRODUCTION RELEASE | 2/27/20 | ZC |

SPECIFICATIONS SUBJECT TO CHANGE WITHOUT NOTICE.

PROJECTION

UNLESS OTHERWISE SPECIFIED DIMENSIONS ARE IN INCHES, TOLERANCES FOR ROUGH AND CLEAR OPENING ± .125 INCH. ALL OTHERS ARE:

| | | | |
|-----|------|-------|--------|
| .X | .XX | .XXX | ANGLES |
| ±.1 | ±.03 | ±.010 | ±2° |

DO NOT SCALE DRAWING

FREEMAN MARINE EQUIPMENT, INC.
 28336 HUNTER CREEK ROAD
 GOLD BEACH, OR 97444 U.S.A.
 PHONE: 541-247-7078 FAX: 541-247-2114
 www.freemanmarine.com

CONFIDENTIAL PROPERTY OF FREEMAN MARINE EQUIPMENT, INC. UNAUTHORIZED USE, REPRODUCTION OR DISTRIBUTION IS STRICTLY PROHIBITED. ALL COPIES REMAIN THE PROPERTY OF FREEMAN MARINE EQUIPMENT, INC. AND MUST BE RETURNED UPON REQUEST.

CLIENT: **FREEMAN MARINE**

TITLE: **WATERTIGHT RAISED SCUTTLE FLUSH COVER**

SIZE: **D** CAGE CODE: **64747** DRAWING NUMBER: **408-MS** REV. **00**

SCALE: 1:5.5 CALC. WT. ACT. WT. SHEET 1 OF 1