

10. FOR SPECIFIC INFORMATION CONTACT SALES.
9. COMPLETE ASSEMBLY WEIGHT W/ DECK RING, 28.0LBS/ 12.7K.
8. DOGGING PRESSURE FULLY ADJUSTABLE.
7. HANDLE POSITION TOPSIDE INDICATES WHETHER DOGGING MECHANISM IS IN OPEN OR CLOSED POSITION.
6. ALUMINUM ALLOY MECHANISM SHOWN.
5. FLUSH, WATERTIGHT CONSTRUCTION.
4. INTEGRAL TOPSIDE "T" HANDLE STANDARD, OTHER TOPSIDE ACTUATION AVAILABLE.
3. STAINLESS STEEL RING CAN BE WELDED.
2. QUICK-ACTING, MECHANISM ENGAGES OR DISENGAGES IN QUARTER-TURN OF CENTER SPINDLE.
1. 12 X 18.0 CLEAR OPENING, ALL DIMENSIONS SHOWN SUBJECT TO CASTING VARIATION AND ARE REFERENCE ONLY.

NOTES: UNLESS OTHERWISE SPECIFIED.

SPECIFICATIONS SUBJECT TO CHANGE WITHOUT NOTICE.		FREEMAN MARINE EQUIPMENT, INC. 28336 HUNTER CREEK ROAD GOLD BEACH, OR 97444 U.S.A. PHONE: 541-247-7078 FAX: 541-247-2114 www.freemanmarine.com	
PROJECTION		CLIENT: FREEMAN MARINE	
UNLESS OTHERWISE SPECIFIED DIMENSIONS ARE IN INCHES, TOLERANCES FOR ROUGH AND CLEAR OPENING ± .125 INCH. ALL OTHERS ARE: .X .XX .XXX ANGLES ±.1 ±.03 ±.010 ±2°		TITLE: HATCH: 1218, AL COVER, SS RING,	
DO NOT SCALE DRAWING		SIZE: D CAGE CODE: 64747 DRAWING NUMBER: 2431-0005 REV. A	
CONFIDENTIAL PROPERTY OF FREEMAN MARINE EQUIPMENT, INC. UNAUTHORIZED USE, COPYING OR DISTRIBUTION IS STRICTLY PROHIBITED. POSSESSOR OF THIS DOCUMENT AGREES TO THE FOREGOING AND SHALL RETURN THIS DOCUMENT UPON REQUEST. © ALL RIGHTS RESERVED 2004		SCALE: 1:2.5 CALC. WT. ACT. WT. SHEET 1 OF 3	
- INITIAL RELEASE 16NOV05 MRS	A UPDATE GEN NOTES & B.O.M. 02AUG11 PPC	DRAWN: M. STENDER DATE: 16NOV09	CHECKED: DATE:
REV. DESCRIPTION: DATE: DRAWN	ENGR: DATE:	DESIGN ACTIVITY: DATE:	CONTRACT NO.:

8 7 6 5 4 3 2 1

D

C

B

A

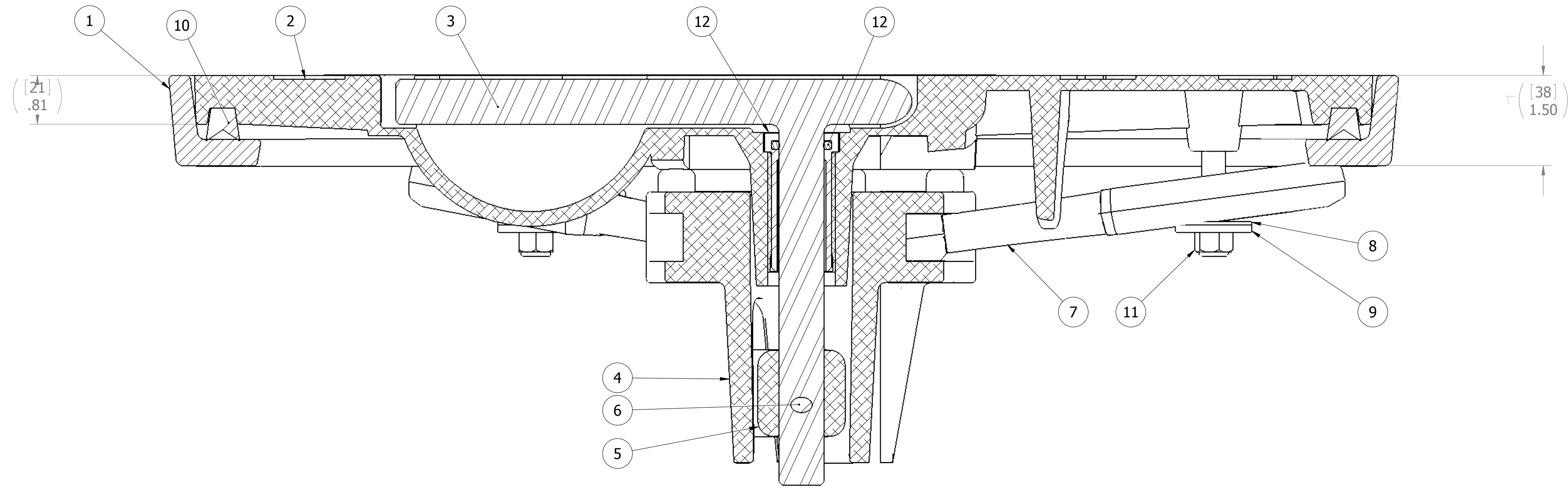

SECTION A-A

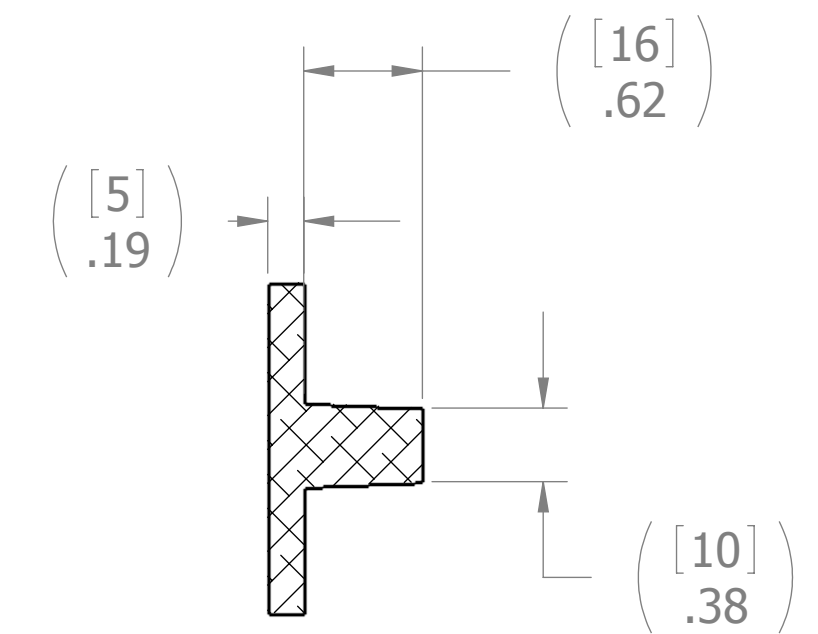

SECTION B-B
SCALE 1 : 1

ITEM NO.	QTY.	PART NUMBER	DESCRIPTION	MATERIAL
12	1	0031-2058	BUSHING ASSY, W/O-RING, NO SLEEVE	REF S.A. BOM
11	4	0411-2032	NUT .375IN NYLOCK	316/316L
10	1	9801-2003	GASKET: 1218 (4.53 FT. OF 0631-9801)	Material <not specified>
9	4	0411-2033	WASHER .406 X 1.25 X .125IN SS 316	316/316L
8	4	0413-2005	WASHER, .406X1.25X.062 NYLON	PTFE (general)
7	4	0211-2002	DOG, LOCKING ARM 1218, AL	535.2-F
6	1	0411-2004	PIN KNURLED .25 X 2.25IN SS 316	316/316L
5	1	0112-2001	ACTUATOR, AL	535.2-F
4	1	0011-2002	HUB, AL, 4 HOLE	535.2-F
3	1	0021-2005	HANDLE, S/S, ROUND BAR	SS 304/304L ANLD
2	1	0111-4116	COVER: 1218	A356.0-F
1	1	2431-1002	316 LIFTOUT STAINLESS STEEL RING	STAINLESS STEEL, 316

SPECIFICATIONS SUBJECT TO CHANGE WITHOUT NOTICE.		FREEMAN MARINE EQUIPMENT, INC.		28336 HUNTER CREEK ROAD GOLD BEACH, OR 97444 U.S.A. PHONE: 541-247-7078 FAX: 541-247-2114 www.freemanmarine.com	
PROJECTION		CONFIDENTIAL PROPERTY OF FREEMAN MARINE EQUIPMENT INC. UNAUTHORIZED USE, COPYING OR DISTRIBUTION IS STRICTLY PROHIBITED. POSSESSOR OF THIS DOCUMENT AGREES TO THE FOREGOING AND SHALL RETURN THIS DOCUMENT UPON REQUEST.		CLIENT: FREEMAN MARINE	
UNLESS OTHERWISE SPECIFIED DIMENSIONS ARE IN INCHES, TOLERANCES FOR ROUGH AND CLEAR OPENING ± .125 INCH. ALL OTHERS ARE:		DATE: 16NOV09		TITLE: HATCH: 1218, AL COVER, SS RING,	
.X .XX .XXX ANGLES ±.1 ±.03 ±.010 ±2°		DRAWN: M. STENDER CHECKED: DATE: ENGR: DATE: DESIGN ACTIVITY: DATE:		SIZE: D CAGE CODE: 64747 DRAWING NUMBER: 2431-0005 REV. A	
DO NOT SCALE DRAWING		CONTRACT NO.:		SCALE: 1:1 CALC WT. ACT. WT. SHEET 2 OF 3	

REV.	DESCRIPTION	DATE	DRAWN
-	INITIAL RELEASE	16NOV05	MRS
A	UPDATE GEN NOTES & B.O.M.	02AUG11	PPC

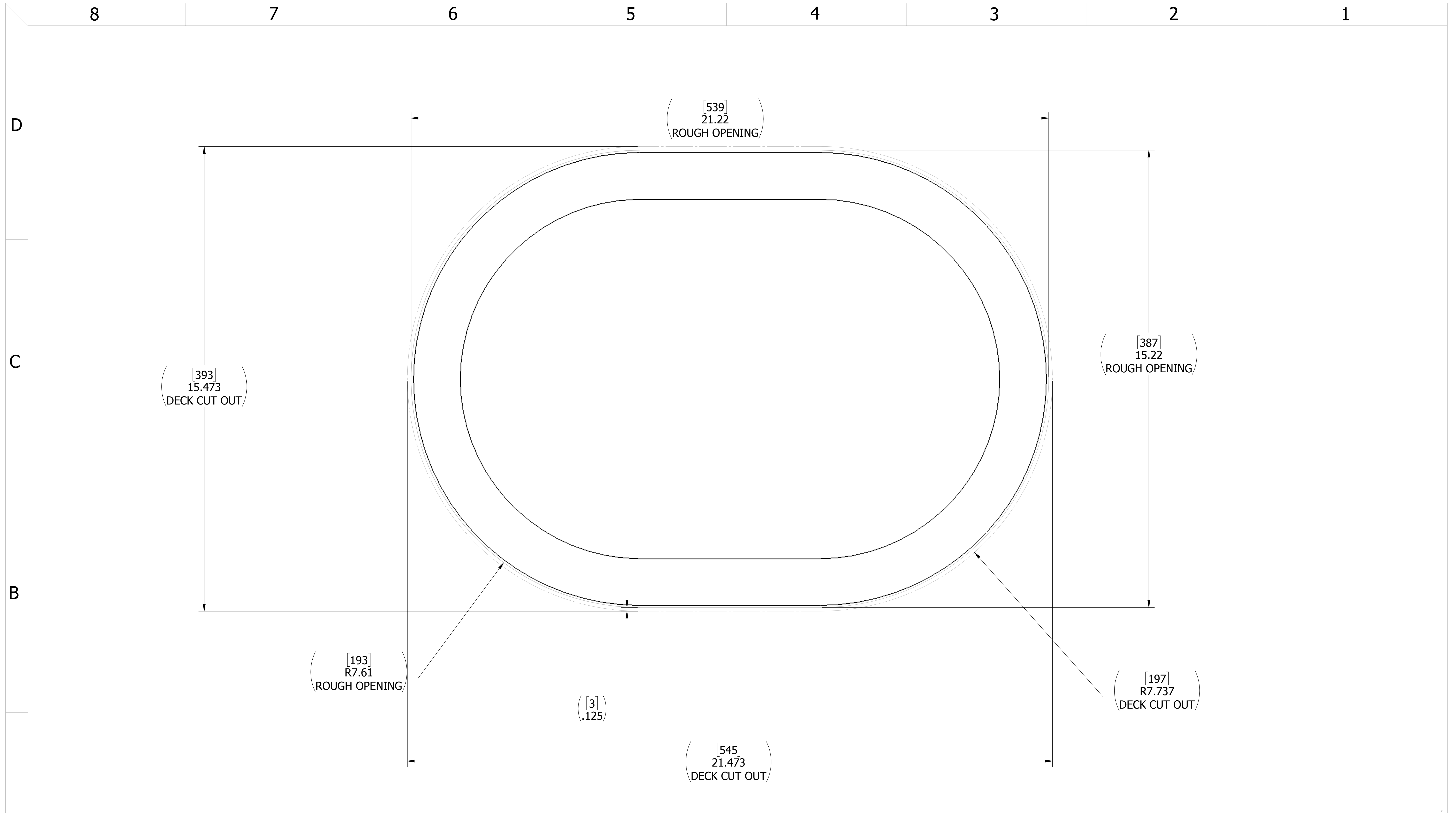

- 3. FINISH: 125 RMS MAX.
 - 2. BREAK SHARP EDGES AND DEBURR.
 - 1. MATERIAL: Material <not specified>
- NOTES: UNLESS OTHERWISE SPECIFIED.

CUSTOMER APPROVAL

Signature: _____
 Date: _____

IMPORTANT! THIS DRAWING SUPERSEDES ALL OTHER DOCUMENTS. By signing this approval you accept and agree that the dimensions and details shown are correct and properly fit your application, regardless of any differences between this drawing and any contract specifications. Should you see any errors in the drawing, or have any questions, please contact your Freeman Marine sales engineer for clarification.

REV.	DESCRIPTION	DATE	DRAWN
-	INITIAL RELEASE	16NOV05	MRS
A	UPDATE GEN NOTES & B.O.M.	02AUG11	PPC

SPECIFICATIONS SUBJECT TO CHANGE WITHOUT NOTICE.

PROJECTION

UNLESS OTHERWISE SPECIFIED DIMENSIONS ARE IN INCHES, TOLERANCES FOR ROUGH AND CLEAR OPENING ± .125 INCH. ALL OTHERS ARE:

.X	.XX	.XXX	ANGLES
±.1	±.03	±.010	±2°

DO NOT SCALE DRAWING

FREEMAN MARINE EQUIPMENT, INC.

CONFIDENTIAL PROPERTY OF FREEMAN MARINE EQUIPMENT, INC. UNAUTHORIZED USE, REPRODUCTION OR DISTRIBUTION IS STRICTLY PROHIBITED. ALL COPIES REMAIN THE PROPERTY OF FREEMAN MARINE EQUIPMENT, INC. AND MUST BE RETURNED UPON REQUEST.

28336 HUNTER CREEK ROAD
 GOLD BEACH, OR 97444 U.S.A.
 PHONE: 541-247-7078 FAX: 541-247-2114
 www.freemanmarine.com

CLIENT: **FREEMAN MARINE**

TITLE: **HATCH: 1218, AL COVER, SS RING,**

SIZE: **D** CAGE CODE: **64747** DRAWING NUMBER: **2431-0005** REV. **A**

SCALE: 2:3 CALC WT. ACT. WT. SHEET 3 OF 3