

EXTERIOR VIEW

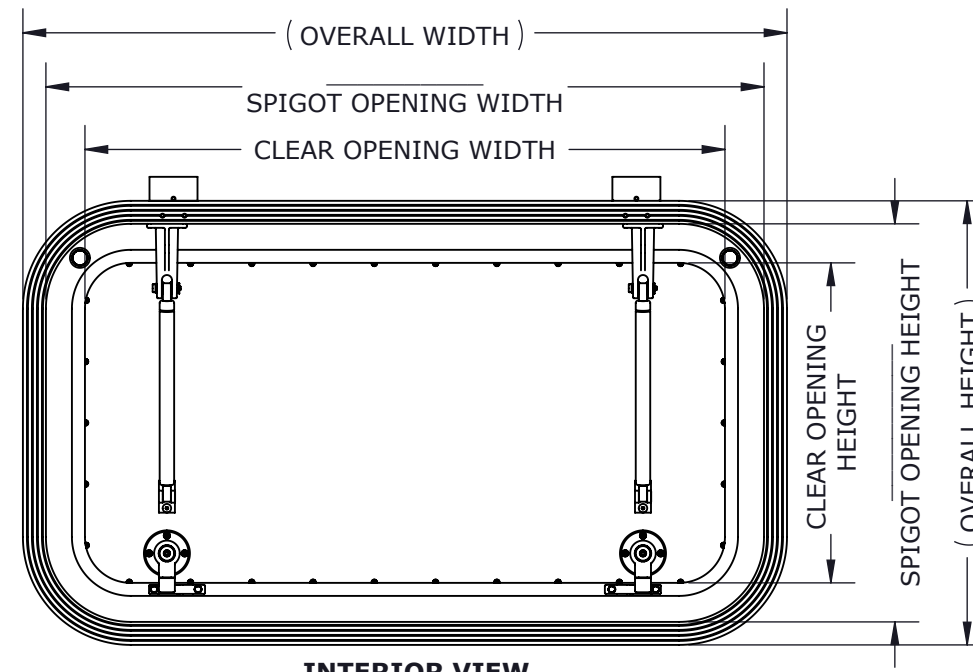

INTERIOR VIEW

$OVERALL = SPIGOT\ OPENING + 73.2mm[2.88in]$
 $CLEAR\ OPENING = SPIGOT\ OPENING - 124.0mm[4.88in]$
 $PLATE\ CUT = SPIGOT\ OPENING + 6.35mm[0.25in]$

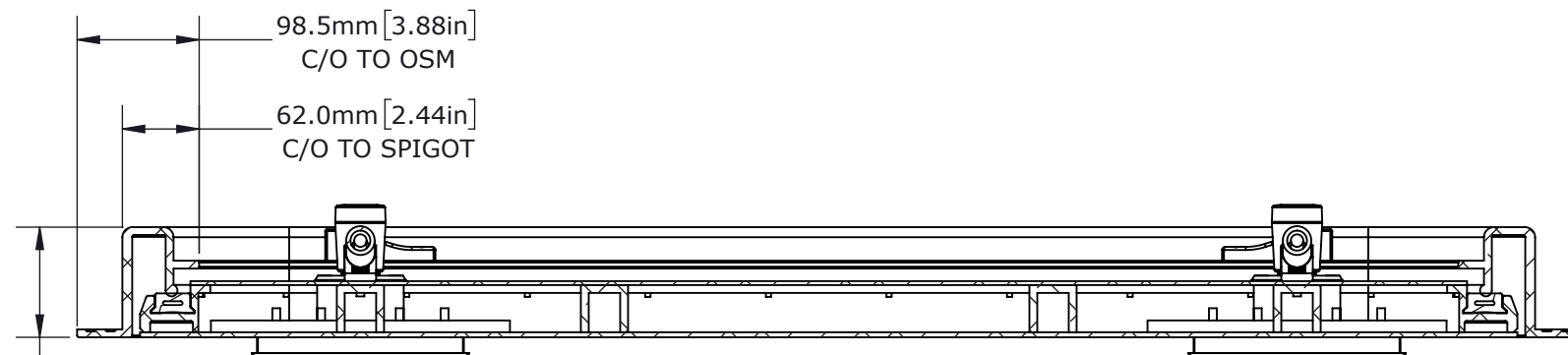

88.9mm [3.50in]
OVERALL DEPTH

SECTION A-A
SCALE 1 : 6

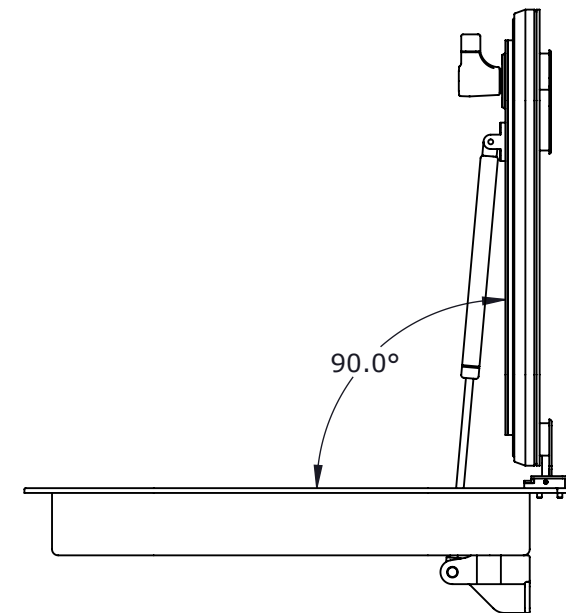

OPTIONS

HANDLE STYLE	HANDLE	
	REMOVABLE WINCH HANDLE	
	BI-SQUARE	
DOG STYLE	LEVER	
	FLUSH/RECESSED POCKET	
FRAME STYLE	BOLT IN	
	WELD IN	
*CORNER TYPE	MITRED	
	ROUND	

CUSTOMER

ADVANTEC

PROJECT

3130 PCM SALES DRAWING

DESCRIPTION

STANDARD 3130 PCM SERIES
MODEL AND DRAWING

CONTACT	DATE
(604) 607-0091	10/6/2020



PACIFIC COAST MARINE

DWG TITLE	CAGE CODE
3130 SERIES HATCH	

DESCRIPTION	QTY
Premium Duty, Individual Dog	

COPYRIGHT 2020 ADVANTEC GLOBAL INNOVATIONS. ALL RIGHTS RESERVED. CONFIDENTIAL PROPERTY OF ADVANTEC GLOBAL INNOVATIONS. UNAUTHORIZED USE, REPRODUCTION OR DISTRIBUTION IS STRICTLY PROHIBITED. COPIES REMAIN THE PROPERTY OF ADVANTEC GLOBAL INNOVATIONS AND MUST BE RETURNED UPON REQUEST.

SCALE	DRAWN	DATE	CHECKED	DATE	SIZE
1:12	SP	10/6/2020			B
S.O. NO	DWG NO	SHEET	REV		
	3130-1 PCM Sales	1 of 1	00		